

FRANKLIN COUNTY ENGINEER

HIGHWAY DESIGN

PROJECT DESIGN QUALITY CONTROL CHECKLIST
FOR REFERENCE ONLY
NOT TO BE INCLUDED AS PLAN SHEET

GENERAL:

1. Give all signature lines equal signing space.
2. For intersection projects involving the names of more than one roadway, list the road that has the lowest county road number first in the title of the plans.
3. The Design Engineer needs to stamp and sign the plans before FCEO signs them.
4. If more than one P.E. is stamping the plan, then add a sentence stating what each P.E. is certifying.
5. Add Revision Block to title sheet for revisions after bid opening. (Columns: Revision, Description, Initial, Date)
6. Include OEPA NPDES number on the title sheet.
7. Include the county's Work ID and Project # on the right margin of plan sheets.
8. Include schematic of the project.
9. Show and label Corp Lines on location map, schematic, and Plan/Profile sheets. Hash the line on the side of the "other" municipality.
10. Use NAVD 88 Datum for vertical control.
11. Use NAD 83, 1986 Adjustment for horizontal control.
12. Use Ground Distances not Grid Distances.
13. List all BM's in a table including description, location, and elevation.
14. Set Temporary BM's every 400' and place them outside of the Work Limits where they will not be removed by construction. Do not place them on power poles that will be relocated, trees that will be cut down, fire hydrants that will be relocated, etc.
15. Do not write General Notes with all CAP's.
16. Make centerline of Construction line up with centerline of R/W at project limits even if they do not line up within the project.
17. If centerline of Construction and centerline of R/W are different, use drastically different Stationing for each one to minimize confusion when referencing cross section Stationing, which is to match Construction Stationing.
18. Include SubSummaries on each Plan/Profile sheet instead of having SubSummaries in a separate location in the plans.
19. Include separate driveway details and a Driveway SubSummary.
20. Do not end widenings abruptly; instead include pavement tapers and reboundable delineators if necessary.

Construction Plans:

1. For roadways that have existing curb/gutter, design full width, full depth reconstructions with a lower profile for positive drainage into the gutters. Do not try salvaging existing pavements by building widenings and new curb/gutter.
2. For roadways that do not have existing curb/gutter, consider a widening design to utilize existing pavement, minimize R/W takes, and simplify MOT. However, look at the existing profile and do what is necessary to solve possible, existing sight distance problems. Saw-cut full depth and seal the longitudinal joint 1' inside the existing edge of pavement (white edge line), build widening thru intermediate course flush with existing pavement, specify profile milling for crown correction that may extend over the new intermediate course, include surface course leveling course as needed, 1.5" intermediate course full width, and 1.5" surface course full width. Include 75' (minimum) of milling at limits of overlay to provide a transverse butt joint.
3. For full depth, full width reconstruction projects, design widening and resurfacing between the ultimate width section and project tie-in point where existing and proposed profiles are nearly the same elevation.
4. Investigate actual pavement grades at tie-in locations at project limits.
5. Include Under Cut items for 25% of the subgrade area calculated at a thickness of 24" with 12" of #2 Stone, 12" 304 aggregate, 2" 304 aggregate choker, and Geotextile Fabric on the bottom.
6. Include Item 410 if there are driveways to be maintained during construction. Calculate 200 CU. YD per plan + 10 CU. YD. per driveway + driveways as directed.
7. If Temporary Pavement is needed, use both Temporary Pavement (SY) and Temporary Road (LS) pay items.
8. Is there any chance of Petroleum Contaminated Soil? If so, include appropriate pay items.
9. Label slopes on cross-sections. Try for 6:1 (4:1 max steepness) along yard sections.
10. Design Flowable Controlled Density Fill (FCDF) as backfill in the bottom of utility trenches (storm sewer, waterline, etc) that are within pavement (or the influence line of pavement) and deeper than 10' up to a point such that the compacted granular backfill the rest of the way up is no deeper than 10'. Specify FCDF, as per Columbus 2018 CMS 613.04 Type I or Type III.
11. If the project includes sidewalks, design 5' (minimum) green space between sidewalk and curb.
12. See separate driveway standards. Verify positive drainage on projects where driveways are removed or relocated.
13. Provide calculations for roadway quantities such as subgrade compaction, aggregate base, asphalt, etc to be used by FCEO Project Engineers. (Do not include the calculations in the plans.)
14. Calculate Subgrade Compaction to include curb/gutter and driveways, as per 2010 ODOT CMS.

Concrete:

1. Specify MS Concrete in curb/gutter through driveways and in driveway aprons. Flag the pay items "As Per Plan" and handle MS Concrete by note.
2. Try not to use Type 6 curb in areas of flat profile grades. OK to use it along driveways to tie into existing curb at the driveway work limits.
3. Use 8" concrete instead of 4" in wheel chair ramps, at side streets, and adjacent to driveways (10' each way).
4. Extend concrete drop curb and gutter sections across all driveways including wide commercial ones instead of trying to move surface water across the driveway in a swale formed by asphalt.

Erosion Control:

1. Include Project Site Plan instead of an SWP3. We are following ODOT's method of having the contractors develop the SWP3's as a pay item.
2. Include the following in the Site Plan:
 - a. Nature and type of construction activity, area expected to be disturbed, impervious area, soil map #, prior land use.
 - b. Names and locations of initial and subsequent surface water bodies receiving storm water discharge.
 - c. Soils types, contours, etc.
 - d. Surface water locations and types.
 - e. Location of existing and planned buildings, roads, parking, and utilities.
3. Follow and reference ODOT PN205, SS832, SS833, and the FCEO Proposal Note.

RR Crossings:

1. Transition out of regular crown section to meet RR tracks as necessary. When calculating the elevations of this transition, allow for a longer, flatter crossing; in other words, if the transition is to be spread out over 25', start it 35' from each steel rail.
2. Transition curb on each side of RR from 6" to 0" in 10'.

R/W Plans:

1. Title - "X" Road - C.R. x & "Y" Road - C.R. y Establishing, Altering and Widening Right of Way

Note to Designer: List road with lowest road # first.

2. List addresses on R/W Plans and Construction Plans.
3. If centerline of R/W is different than centerline of Construction, show both on R/W Plans and Construction Plans with centerline of R/W bolder on R/W Plans and centerline of Construction bolder on Construction Plans. Also, label and reference STA/Offsets from centerline of R/W on R/W Plans and from centerline of Construction on Construction Plans. Dimension the offset between the centerlines and show where the centerlines come back together listing the STA of each centerline at the points of divergence and convergence. The centerlines should come back together at or near the project limits. In general try to offset the centerlines at even one foot increments in sections where they are parallel to each other.
4. Show existing and proposed R/W and temporary Easements on cross-sections.
5. On any parcel where additional R/W is proposed and there is an existing structure within 60 feet of the proposed R/W, show the distance between the proposed R/W and the closest point on the structure (includes awnings, porches, canopies, etc.)
6. Pick up PRO on any parcel where additional R/W is proposed.
7. All R/W and temporary easements will be acquired in the name of Franklin County Commissioners unless otherwise noted.
8. When designing R/W acquisitions, set new R/W line offsets at even 5' increments.
9. The Franklin County Engineer's Office, Survey Department will monument all R/W acquisitions with 5/8" rebar 30" long with yellow plastic caps stamped "Franklin County Engineer." These pins shall be denoted on the R/W plans and in the Descriptions. Contact Dave Pearson at (614-525-3050) for sample Descriptions.
10. Cross out trees to be removed in Existing and Proposed R/W and label ones to be saved as necessary on R/W Plans and Construction Plans; both plans should be identical.
11. Show and label Work Limits, Existing R/W, Proposed R/W, and Temp R/W on both R/W Plans and Construction Plans. Label the different lines by leaving a gap in each line and putting the label in that gap. Do not put the label above, below, or elsewhere even with a leader.
12. Field check: driveways (make sure all have been accounted for and list composition), side streets that may have been recently built, business signs, fences, trees, side swales between normal cross-sections, etc for both R/W Plans and Construction Plans.
13. Try to design all driveways with a grade of 8% or less. Design driveway replacements all the way to the buildings if necessary to obtain 8% or to minimize the grade as much as possible if physically unable to attain 8%.
14. Investigate existing sanitary conditions and check for upcoming sanitary projects. Check with Stephen Renner, Franklin County Sanitary Engineers Director (614) 525-5850; Gary Young Franklin County Board of Health (614) 525-3909; and Tim Fallara, City of Columbus 645-6728.
15. Investigate existing waterline conditions and check for upcoming waterline projects by contacting Tim Huffman, City of Columbus DOPW (614) 645-7677.
16. If right-of-way impacts are likely to cause the removal of a structure, or any part thereof, consult with the FCEO staff before addressing it in the plans. Asbestos inspection and building removal may have to be added as pay items in the Construction Plans.

Storm Sewers:

1. 5-yr Full Pipe Design and 10-yr Hydraulic Grade Line Check
2. Design the STA/Offset and TC elevation of curb inlets to be the grate elevation at the face of curb. Include a schematic clearly showing this.
3. Include the extra sump at curb inlets as called for on ODOT standard drawings.
4. Check for curb inlets at low points in intersection returns and places where EOP slopes thru an intersection but may have water trapped at the face of curb.
5. Do not allow 707.33 storm sewer for either of the following:
 - If the cover is less than 42".
 - For any run (back to the closest structure) of storm sewer that has an exposed end.

6. Watch for surface drainage getting caught in fill areas where existing ground is lower than and slopes towards roadway.
7. Investigate actual elevation, size, slope, condition, and capacity of existing storm sewers that are tied into as outlets for the project drainage.
8. When storm sewers cross driveways, label the whole run Type B for compacted granular backfill.
9. Show flow arrows and label size of proposed storm sewers in Plan/Profile sheets.
10. In plan view, show storm sewers less than 24" diameter as a single line and use double lines for storm sewers 24" and larger.
11. Do drainage studies on existing culverts and pipe crossing that are to be left in-service.
12. Place CB's halfway between driveways on short runs and minimize ditch depth unless volume in ditch is critical.
13. When tying into existing catch basins at the project limits, bury them as junction chambers with solid, slab tops and set new catch basins further from roadway to allow more gradual side slopes.
14. Include storm sewer crossings and cut outs for Under Drains on cross sections.
15. Show other storm sewer profiles in a separate section in the plans.
16. Do not show existing catch basin removals without also showing existing storm sewer and what is to be done with it—removal or tie-in.
17. Add curb inlets on each side of side streets to improve drainage in radius returns.
18. Do not outlet proposed roadway drainage into an existing system without investigating the condition of the existing system - especially when it is off R/W.

Traffic:

1. Reference the most current Columbus Spec's for projects that include street lighting.
2. List signal strain pole foundation elevations.
3. List traffic pull box elevations as is done for catch basins.
4. Provide calculations for signal quantities such as conduits, loops, wire, etc to be used by FCEO Project Engineers. (Do not include the calculations in the plans.)
5. Label lane widths on striping plans.

Wheel Chair Ramps:

1. Draw general shape of the ramps in the plans, but do not list elevations. If the City of Columbus is reviewing the plans, they require detail design of ramps which include elevations.
2. Reference the most recent Columbus specs.

Waterline Work:

Note to Designer: Provide sufficient hydrant relocation as needed for MOT

1. Do not call out "Valve Box Adjusted to Grade" pay item when calling for "Heavy Duty Valve Box" because that pay item includes adjusting it to grade.
2. Call out 6" valve and 6" waterline pay items along with Fire Hydrant Relocation pay items. They are itemized and paid for separately.
3. If a Fire Hydrant Relocation places the fire hydrant further than 10' from the existing 6" valve, then add another 6" valve at the fire hydrant.
4. Specify Class 53 Ductile Iron Pipe for waterlines less than 12" and Class 54 for waterlines 12" and larger.
5. For waterlines 20" and larger label the pay item as "Class 54 Ductile Iron Pipe or Prestressed Concrete Pipe."

INDEX OF SHEETS

PROJECT DESIGN QUALITY CONTROL CHECKLIST	1
TITLE SHEET (CAPITAL IMPROVEMENT)	2
TITLE SHEET (BRIDGE / CULVERT)	3
TITLE SHEET (RIGHT-OF-WAY)	4
TITLE SHEET (PRIVATE DEVELOPMENT)	5
SURVEY CONTROL NOTES	6
GENERAL NOTES	7-11
MAINTENANCE OF TRAFFIC NOTES	12-13
STREET LIGHTING NOTES	14
TRAFFIC CONTROL NOTES	15
TRAFFIC SIGNAL NOTES	16-17
BRIDGE / CULVERT NOTES	18-20
TYPICAL PAVEMENT SECTION FOR COLLECTOR AND ARTERIAL ROADS	RD-01
TYPICAL PAVEMENT SECTION FOR UNCURBED LOCAL ROADS	RD-02
TYPICAL PAVEMENT SECTION FOR CURBED LOCAL ROADS	RD-03
TYPICAL PAVEMENT SECTION & SCHEMATIC PLAN FOR A ROUNDABOUT	RD-04
SPLITTER ISLAND & LANDSCAPE DETAILS FOR A ROUNDABOUT	RD-05
PAVEMENT DETAILS	RD-06
CURB DETAILS	RD-07
DRIVEWAY DETAILS	RD-08
SIDEWALK & SHARED-USE PATH DETAILS	RD-09
CUL-DE SAC, EYEBROW & TURN-AROUND DETAILS	RD-10

FRANKLIN COUNTY MONUMENT DISTURBANCE

The Contractor shall contact the Franklin County Engineer's Office Survey Department at (614-525-2489) a minimum of two (2) working days before disturbing any Franklin County Geodetic Monuments (Horizontal and/or Vertical) for reference and possible replacement.

FRANKLIN COUNTY MONUMENT ASSEMBLY

The contractor shall contact the Franklin County Engineer's Office Survey Department at (614-525-2489) a minimum of five (5) working days in advance of final surface course paving operations for monument setting procedures.

FRANKLIN COUNTY MONUMENT BOX-OUT

The Contractor shall contact the Franklin County Engineer's Office Survey Department at (614-525-2489) a minimum of five (5) working days prior to paving concrete base to coordinate box-outs for resetting county monument.

Note to Designer: Only for projects with Concrete Base.

EXISTING SURVEY MONUMENT REMOVAL, AS PER PLAN

Carefully remove the monument and surrounding concrete foundation. Fill the hole with Flowable Controlled Density Fill, as per Columbus 2018 CMS 636.04 Type I or Type III. Contact the Franklin County Engineer's Office, Survey Department at (614-525-2489) for pick-up of existing monument. If existing monuments are FCE monuments, then FCE Survey Crew will reset them in the original location. Coordinates and bearings shown in plans are based on the Ohio State Plane Coordinate System, South Zone, NAD83 (20** Adjustment).

Note to Designer: Only for projects that have monuments in the way of proposed construction that will be reset by FCEO Survey Department. Add corresponding pay item, ITEM SPECIAL, and quantity [EACH] to the General Summary.

HORIZONTAL DATUM

NAD83 (NSRS 2007)
Coordinates listed are (project) ground coordinates values based on the Ohio State Plane Coordinate System, South Zone, North American Datum 1983 (NSRS 2007) referenced to XXXX and XXXX published grid values with a combined scale factor from grid to ground of X.XXXXX.

NAD83 (2011)
Coordinates listed are (project) ground coordinates based on the Ohio State Plane Coordinate System, South Zone, North American Datum 1983 (2011) referenced to XXXX and XXXX published grid values with a combined scale factor from grid to ground of X.XXXXX.

NAD83 (2011) - OCCS
Bearings shown hereon are based on the on the Ohio County Coordinate System, Franklin County, and North American Datum of 1983 (2011) as established from a GPS survey originating on ODOT CORS Station "COLB" with a bearing of XXXXXX as shown along the centerline of XXXXX.

VERTICAL DATUM

NAVD88 (traditional)
All Elevations are on the North American Vertical Datum of 1988 (NAVD88) as established from an actual field survey in Month YEAR with reference to the following control monument(s):

LIST SOURCE VERTICAL(s) with ELE in BOLD
All other site benchmarks with ELE below source in BOLD

NAVD88 (GPS)
All Elevations are on the North American Vertical Datum of 1988 (NAVD88) as established from a GPS survey originating on ODOT CORS station "COLB" using Geoid Conus XXX with reference to the following control monument(s):

LIST SOURCE VERTICAL(s) with ELE in BOLD
All other site benchmarks with ELE below source in BOLD

NAD83 (2011)
All Elevations are on North American Datum 1983 (2011) as established from a GPS survey originating on ODOT CORS station "COLB" using Geoid Conus XXX with observance to the following control monument(s):

LIST VERTICAL(s) with ELE below source in BOLD

BASIS OF BEARINGS

Traditional
Bearings shown hereon are based on the on the Ohio State Plane Coordinate System, South Zone, and North American Datum of 1983 (NSRS 2007), as established from a GPS survey performed by the Franklin County Engineer's Survey Department in XXXX, Occupying monuments "xxxx" & "xxxx" with a bearing of XXXXXX as shown along the centerline of XXXXX.

NAD83 (2011)
Bearings shown hereon are based on the Ohio State Plane Coordinate System, South Zone, and North American Datum of 1983 (2011) as established from a GPS survey originating on ODOT CORS Station "COLB" with a bearing of XXXXXX as shown along the centerline of XXXXX.

NAD83 (2011) - OCCS
Bearings shown hereon are based on the Ohio County Coordinate System, Franklin County, and North American Datum of 1983 (2011) as established from a GPS survey originating on ODOT CORS Station "COLB" with a bearing of XXXXXX as shown along the centerline of XXXXX.

DRAWN BY ACK
CHECKED JDH

DATE 01/01/2025

SURVEY CONTROL NOTES

FRANKLIN COUNTY ENGINEER

DESIGNER NOTE:

These general notes are specific to Franklin County Engineers Office (FCEO) Capital Improvement Projects (CIP) and shall be used as dictated by the project scope. These County required notes do not constitute a complete project note set. All other required General Notes shall be incorporated into the project plans as set forth in the Ohio Department of Transportation (ODOT) Location and Design Manual, Current Edition.

References made to Construction and Material Specifications shall be from the current edition of the ODOT CMS unless otherwise noted. Check all notes for references to standard drawings and make sure they are included in the Title Sheet Standard Drawing Table.

SPECIFICATIONS

The 2023 Construction and Material Specifications of the State of Ohio, Department of Transportation, including changes and Supplemental Specifications listed in the proposal, shall govern this improvement, except where noted otherwise.

WORK LIMITS

The work limits shown on these plans are for physical construction only. Provide the installation and operation of all work zone traffic control and work zone traffic control devices required by these plans whether inside or outside these work limits.

HOURS OF OPERATION

Contractor's work hours shall be limited to 7:00 A.M. to 7:00 P.M. Monday through Saturday, unless permission is granted by the Engineer in writing. The Contractor shall be required to adhere to all local noise ordinances.

PRECONSTRUCTION MEETING AND EEO--PREVAILING WAGE SESSION

The contractor shall meet for a preconstruction meeting scheduled by the County as per Franklin County General Provision 108.02. An EEO--prevailing wage session will be held in conjunction with the general preconstruction meeting discussion of contract documents, affected third party concerns, schedule, proposed subcontractors--suppliers submittals, etc.

PREVAILING WAGES

Prevailing Wage paperwork required of the Prime Contractor and Sub-Contractors shall be current and up-to-date for work performed. Pay Estimates will be considered incomplete and unpayable until the associated Prevailing Wage paperwork is submitted to the Franklin County Engineer's Prevailing Wage Coordinator contact 614-525-5123 for Federal or State wage rate provisions relating to prevailing wages shall reference:

State: <http://www.com.ohio.gov/dico/>
Federal: <http://www.wdol.gov/dba.aspx>

NON-COLLUSION AFFIDAVIT

In accordance with Title 23 United States Code, Section 112 and Ohio Revised Code, Chapter 1331 et. seq. and Sections 2921.11 and 2921.13, the bidder hereby states, under penalty of perjury and under other such penalties as the law provides, that the bidder or the bidder's agents or employees have not entered either directly or indirectly into any agreement, participated in any collusion, or otherwise taken any action in restraint of free competitive bidding in connection with this proposal. Execution of this proposal on the signature portion thereof shall constitute also signature of this Non-Collusion Affidavit as permitted by title 28 United States Code, Section 1746.

MAINTAINING AND REPLACEMENT OF MAILBOXES

In addition to the requirements of section 107.10 of the Franklin County General Provisions, the Contractor shall carefully remove the mailboxes and offer them to the property owners for later installation. The Contractor shall install temporary mailboxes during construction. If the property owners decide not to reuse the mailboxes, the Contractor shall replace the existing mailboxes with material supplied by the Franklin County Engineer. At a minimum they should be replaced with a 4"x 4" wood post and steel box. The Contractor shall install the mailboxes in accordance with postal regulations. The Contractor shall obtain the necessary materials at 970 Dublin Rd, at which time details and installation requirements shall be furnished. Payment shall be included in the price bid for Item 690.

SAFETY REQUIREMENTS AND RESPONSIBILITIES

The Contractor is responsible for ensuring that all work under this contract meets or exceeds the Occupational Safety & Health Administration (OSHA) standards in addition to complying with the recognized best practice within the construction industry.

1.0 Contractor Responsibility

The Contractor alone shall be responsible for the safety, efficiency, and adequacy of the work location, equipment, materials, and methods, and for any damage that may result from their improper construction, maintenance, or operations. The Contractor shall erect and properly maintain at all times, as required by the conditions and progress of the work, proper safeguards for the protection of workers and the public and shall post danger warnings against any hazards created by the construction operations. The Contractor shall be responsible for the compliance of all Subcontractors according to these requirements.

2.0 Certification Requirements

The manufacturer of safety systems (shoring, protective systems, fall protection) or a professional engineer (PE) must certify that the design of major or critical facilities, equipment, support structures, or systems, embankments, shoring systems, and formwork (false work) is structurally suitable for the intended use. This certification must be in writing and submitted to the FCEO Project Manager before construction or use of such facilities, equipment, or support systems.

3.0 Competent Person

The Contractor is responsible for identifying the need for Qualified and/or Competent Persons for specific tasks as defined in 29 CFR 1926.

4.0 Subcontractor Compliance

The Contractor is responsible for screening all Subcontractors with respect to these safety requirements and responsibilities. In addition, the Contractor is responsible for monitoring and enforcing compliance of all Occupational Safety and Health Administration (OSHA) requirements to its Subcontractors. The Contractor shall be responsible for ensuring conformance of all subcontractors to the Contractor's comprehensive safety program.

5.0 Safety Supervisor

The Contractor shall designate, in writing, a Safety Supervisor responsible for administering the comprehensive safety program on-site. The Safety Supervisor shall have supervisory authority over the Contractor, Subcontractors, and suppliers. The Safety Supervisor shall have the responsibility for site safety and workers' health and shall have the authority to correct deficiencies and stop work, if necessary, until deficiencies are corrected. The Safety Supervisor shall immediately notify the FCEO Project Manager if/when an OSHA Inspector arrives on site.

6.0 CPR and First Aid

The Contractor shall have on site at all times when work is being performed at least one individual certified in CPR and First Aid.

7.0 Refusal to Comply with Occupational Safety and Health Requirements

The Contractor must remove employees who refuse or repeatedly fail to comply with safe work practices and standards, or supervisors who fail to enforce compliance with the associated work assignments.

8.0 Contractor and Subcontractor Reporting

The Contractor and Subcontractors shall comply with all legal and FCEO specific reporting requirements relating to Environmental Health and Safety (EHS) set forth in the Contract Documents. The Contractor will immediately report orally, and in writing within two (2) days, any EHS related loss, damage, or accident arising from the work to the FCEO Project Manager. The Contractor and its Subcontractors will immediately report to the FCEO Project Manager all non-incidentals spills, and all other significant impacts to the environment (soil, water, air) in performance of the work. The Contractor will also immediately notify the FCEO Project Manager of any "failure to comply" with state and federal environmental laws, rules, and regulations.

9.0 Safety and Health Reporting

The Contractor's designated Safety Supervisor shall report all injury accidents and incidents to the FCEO Project Manager as they occur. If a death, hospitalization, amputation, loss of an eye, or injury involving a serious medical condition occurs, the incident shall be reported to the FCEO Project Manager within 30 minutes by the General Contractor's Safety Supervisor. Results of accident investigations and corrective actions shall be provided to FCEO Project Manager as soon as practical following the investigation.

10.0 Incident Investigation

In the event of an incident, the Contractor will conduct an incident investigation. The investigation will include a written report summarizing the results of the investigation, corrective actions taken to prevent a reoccurrence, and any lessons learned. The FCEO, may at its discretion, participate in and facilitate the incident investigation. Time and expense incurred by the Contractor performing an incident investigation will be at the Contractor's expense.

11.0 Progress Meeting - Safety

The FCEO Project Manager, the General Contractor's principal onsite representative, and designated members of respective staff responsible for safety will review site safety concerns at the Progress Meetings. The safety segment of the meeting will review the Contractor's safety effort, resolve health and safety problems relating to current operations, and provide a forum for planning safe future activities. The Contractor must be prepared to discuss in detail the procedures to control the hazards likely to happen during major phases of the work, and the organizational assignments involved in administering the comprehensive safety program.

12.0 Work Stoppage

If the FCEO Project Manager perceives the Contractor has created or is exposed to an imminent danger or a non-compliance situation, the FCEO Project Manager will suspend work until safe conditions are re-established. Such work stoppages will be at the expense of the Contractor and will not add cost or time to the completion date of the Contract.

13.0 Contractor's Expense

The Contractor, at its own cost and expense, shall undertake all necessary and appropriate efforts to prevent accidents at its work sites, including the placing and maintenance of proper guards, fences, barricades, security personnel and suitable and sufficient lighting. Safety deficiencies discovered after the award will be remedied at no cost to the FCEO and may, at the FCEO's discretion, be deducted from the contract amount.

14.0 Generated Waste

The Contractor shall manage all waste in performance of the Work in compliance with state and federal law. Further, the Contractor shall attempt to minimize the generation of all wastes and hazardous substances. All disposal and clean-up costs of spills of hazardous substances and non-hazardous debris/waste generated by the Contractor in the performance of the work will be at the expense of the Contractor.

EXPOSE NOTE

Where plans provide for a proposed conduit, storm sewer, waterline, or other construction to cross over or under an existing sewer or underground utility, the contractor shall locate the existing pipes or utilities both as to line and grade before starting to lay the proposed conduit, storm sewer, waterline, or other construction. If it is determined that the existing conduit or existing appurtenance to be connected differs from the plan elevation or results in a change in the planned work, the engineer shall be notified before starting construction of any portion of the proposed work which will be affected by the variance in the existing elevations. Payment for all the operations described above shall be included in the contract price for the pertinent items.

ITEM SPECIAL, HYDRO-EXCAVATING UTILITY EXPOSURE

The Contractor shall expose utilities as directed by the Engineer utilizing Hydro-Excavating methods. The unit price bid for this pay item shall be per exposure hole and include all costs for mobilization, labor, equipment, backfill of the exposure holes utilizing Flowable Controlled Density Fill as per Columbus 2012 CMS 613.04 Type I or Type III, and any incidentals necessary to complete the work.

This is a special pay item to be used as directed by the Engineer and not to be used for usual utility exposures associated with OUPS tickets and general construction of the project. Costs to expose utilities associated with OUPS tickets and general construction of the project shall be included in the unit bid prices for the items of work affected. The Contractor is reminded to keep his/her OUPS ticket updated according to industry practices.

A contingency quantity of: ITEM SPECIAL HYDRO-EXCAVATING UTILITY EXPOSURE XX Each has been included in the General Summary for purposes described in this note.

Note to Designer: Add this note to all highway projects and add to bridge projects if requested by FCEO.

SUBSURFACE INVESTIGATIONS

Subsurface investigation reports prepared for the Franklin County Engineer are used strictly for design purposes. The boring information in these reports represents conditions at the specific locations where the borings were taken and may not be representative of conditions throughout the project limits, or reflective of seasonal changes. Disturbances by other activities conducted between the time borings were taken and bid time may also affect subsurface conditions. To ensure a representative overview of subsurface conditions, bidders may wish to conduct subsurface investigations including borings at their own expense. Contractor's bid prices shall reflect any uncertainty with subsurface soil conditions and existing pavement conditions. The removal of man-made obstructions such as structure foundations, utilities, and pipes not shown on the plans are eligible for extra compensation. The bidder shall take into consideration in his unit bid price, man-made obstructions shown in the plans such as structure foundations, utilities, and pipes. No extra payment shall be made for variable soil conditions, which may be encountered. The bid prices for Pavement Removal and Excavation items shall reflect the removal of all paving materials (asphalt, concrete, brick, stone, wood) at all locations on the project. The Contractor is responsible for determining the existing pavement composition by reviewing his own subsurface investigations, existing plans (if available), and soil reports prior to bidding. Contact the following office for further information:

Franklin County Engineer's Office
970 Dublin Rd.
Columbus, OH 43215
(614) 525-3036

Note to Designer: Contact Design Services Department to get name and number of contact person for project

GENERAL NOTES

FRANKLIN COUNTY ENGINEER

DATE: 01/01/2025
DRAWN BY: ACK
CHECKED: JDH

DESIGNER NOTE:

These general notes are specific to Franklin County Engineers Office (FCEO) Capital Improvement Projects (CIP) and shall be used as dictated by the project scope. These County required notes do not constitute a complete project note set. All other required General Notes shall be incorporated into the project plans as set forth in the Ohio Department of Transportation (ODOT) Location and Design Manual, Current Edition.

References made to Construction and Material Specifications shall be from the current edition of the ODOT CMS unless otherwise noted. Check all notes for references to standard drawings and make sure they are included in the Title Sheet Standard Drawing Table.

BUY AMERICA BACKGROUND AND WAIVER REQUEST PROCESS

FHWA regulations require the use of domestic steel and iron in all projects. All foreign steel and iron materials and products are covered by Buy America, for manufactured products Buy America applies when the product contains more than 90% steel or iron content. All manufacturing processes must take place domestically. Manufacturing begins with the initial melting and mixing, and continues through the coating stage. Any process which modifies the chemical content, the physical size or shape, or the final finish is considered a manufacturing process. These processes include rolling, extruding, machining, bending, grinding, drilling and coating. "Coating" includes epoxy coating, galvanizing, painting, or any other coating that protects or enhances the value of the material.

The practice of making otherwise eligible items nonparticipating for the purpose of circumventing the Buy America requirements is unacceptable and will not be approved in Federal-aid projects. FHWA's policy for Buy America provides for:

- a domestic manufacturing process for any steel or iron products (including protective coatings) that are permanently incorporated in any project funded under Title 23
• alternate bid provisions
• minimal usage criteria for non-domestic products
• a waiver process based on public interest or the availability of domestic products

Before submittal of a Buy America Waiver Request the following questions need to be addressed:

- What is the total cost of the foreign steel or iron to be incorporated into the final project?
o The cost is the cost of the steel itself and installation, not the cost of the entire item
• Does the incidental use guideline cover the use of foreign steel or iron?
o This is the greater of \$2,500 or 0.1% of the total project cost
• Are there equivalent domestic steel or iron parts or items available?
• Are there suppliers of the item that can meet the Buy America requirements?
• Does the Waiver for Manufactured Products containing less than 90% steel or iron content apply?

The preceding questions form the basis needed to consider whether or not a waiver request could be successful. Discussions should be held with FHWA as soon as possible if meeting Buy America requirements are a project concern. Depending upon the items being considered there may be additional questions that need to be addressed before deciding a waiver request should be developed for the project. If the waiver process must be used it takes a significant amount of time, there is no guarantee that a waiver will be approved, and no delay claims for additional time or money will be considered if the contractor elects to pursue the Buy America Waiver process.

Waiver Request Process

The request is prepared in the form of a letter and supporting information. The following information must be provided for all potential Buy America Waiver Requests:

- the PID,
• project description,
• project cost, waiver item,
• cost of waiver item,
• country of origin of the product (if known at the time),
• reasons for the waiver request,
• a description of the efforts made to locate a domestically manufactured product,
• an analysis of re-design of the project using alternate or approved equal domestic product.

The Buy America Waiver Request is submitted to the FHWA Ohio Division for initial review by ODOT along with a letter of concurrence if it is being submitted by a sub-recipient. The Ohio Division is responsible for ensuring that the request includes the necessary information and is acceptable prior to submitting the waiver request to the FHWA Headquarters Office of Program Administration for final review and public comment.

After a review of the waiver is completed a notice of a waiver request is posted on this website, http://www.fhwa.dot.gov/construction/contracts/waivers.cfm, to solicit public comments on the intent to issue a waiver for a 15-day period. Following this comment period, a notice will be published in the Federal Register documenting the finding regarding the waiver. The effective date of the finding will be the date following publication in the Federal Register. Upon publication of the Federal Register notice, the public may submit comments on this finding to this website for an additional 15 days following the effective date of the finding.

All public comments received in the initial 15-day comment period during the final evaluation of the waiver request will be considered prior to making a finding. Comments received after the 15 day period, but before notice of the finding is published in the Federal Register, will be considered to the extent practical. Follow-up coordination on the comments received may result in a delay in the publication of waiver finding in the Federal Register. Comments received during the 15-day comment period after notice of our finding is published in the Federal Register will be reviewed, but the finding will continue to remain valid. Comments received during the comment period after the effective date of the finding will be reviewed, and may influence the FHWA's decision to terminate or modify a finding.

Additional information is available at http://www.fhwa.dot.gov/construction/contracts/buyam_qa.cfm.

If Federal Funds are included. Contact Planning and Programming Engineer 614-525-3020 to verify.

CITY OF COLUMBUS STREET LIGHTING (If COC street lights are included.)

The general contractor is to contact Scott Wolfe at 614-724-4351 email: sawolfe@columbus.gov prior to beginning any wiring operations for a review of wiring procedures in the field with the electrical subcontractor. The electrical subcontractor's qualified representative is to be present with the Division of Electricity and Franklin County for a final inspection of the electrical installation. Also, the electrical subcontractor is to fill out the inspection sheets required by the Division of Electricity for inventory and tests of the installation items.

ASPHALT, FUEL, & STEEL PRICE ADJUSTMENT ALLOWANCE

This item is a fixed amount for all bidders to be utilized for the following potential Price Adjustments:

- Asphalt Binder Adjustment per ODOT PN 534
• Fuel per ODOT PN 520
• Steel per ODOT PN 525

Use of any portion of this item must be approved in writing by the Franklin County Engineer, Chief Deputy Engineer, and Construction Engineer in Change Order format.

MATERIALS

- A. All precast concrete pipe and products are subject to inspection during casting at the plant by the County Engineer's agent - City of Columbus, Inspection Division. All precast concrete pipe and products delivered to the job shall have a stamp by the City of Columbus, Inspection Division with their approval marking. All products manufactured off-site must still meet specifications when delivered and installed at the project. All materials and miscellaneous items incorporated into the precast concrete items shall be from stockpiles for which an ODOT approved lab report can be produced. Items in this category not pre-approved will require testing which will delay permitted use of the material and for which the Contractor is not entitled to a time extension. The proposed manufacturer shall be submitted to the Engineer for approval in writing so an inspection can be made of the proposed plant operations to determine if the applicable specifications referenced in the contract will be met. All manufacturing plant operations must continue to meet applicable specifications at all times.
B. Other Materials shall be in accordance to the ODOT-CMS. All materials shall be from stockpiles for which an ODOT Daily Source Report or City of Columbus Laboratory Report (for City CMS items) can be furnished to the Engineer.

CONCRETE DELIVERY FOR ALL CONCRETE WORK

The use of dump trucks or any other non-agitating vehicles to deliver concrete to the project site is prohibited. Only concrete mixer trucks with agitating bodies specifically designed to haul concrete and approved for use by the Engineer shall be permitted to deliver concrete to the project site. Before delivery, a concrete washout area shall be constructed per Item 832. Contractor to provide location of washout 24hrs before any scheduled pour.

CONCRETE PAVEMENTS, WALK, AND CURB RAMPS

All concrete base and finish pavements placed as per Item 305 and Item 451 shall have joints constructed in accordance to the ODOT Standard Drawing BP-2.1 for Longitudinal Pavement Joints and BP - 2.2 for Transverse Pavement Joints using the load transfer dowel steel shown in the drawings.

All concrete placed as per Item 452 and Item 608 shall follow Table 499.03-1 of the ODOT Construction and Materials Specifications with no slag or fly ash allowed.

As per ODOT 451.11 Contractor is responsible for curing, replacing vandalized concrete and other incidentals such as expansion joint placement, expansion material around manholes etc if within the sidewalk/curb ramp

Note to Designer: Flag Item 452 and Item 608 As Per Plan

ITEM 619 FIELD OFFICE, AS PER PLAN

The field office shall meet the requirements of ODOT CMS 619, placed and set up, including utility service hookups, prior to the start of Construction. No Contractor operations will be permitted in the field office provided to the County, nor shall any Contractor equipment be stored in the field office provided to the County.

The Contractor shall provide the field office with outdoor sealed containers of the capacity necessary to place field office and project trash. The containers are to be emptied by the contractor by legal means on a weekly basis.

All work listed in this section shall be performed by the Contractor and paid under the unit price bid for ITEM 619, FIELD OFFICE, TYPE (), AS PER PLAN. All equipment provided by the Contractor for use by the County under the wording of this section shall remain the property of the Contractor.

ITEM 832, STORM WATER POLLUTION PREVENTION PLAN and ITEM 832, EROSION CONTROL

This contract is subject to National Pollutant Discharge Elimination System (NPDES) and specifically the Ohio EPA Authorization for Storm Water Discharge Associated with Construction Activity under NPDES. Additionally, federal, state, and local regulations pertaining to storm water pollution prevention shall also apply.

An officer of the Contractor's company will be required to co-sign the Ohio EPA permit and Notice of Intent (NOI) as per NPDES requirements (if required). The Contractor shall have a supervisory employee onsite who is competent in proper, current erosion control practices during all earth disturbing activities. It is the Contractor's responsibility to notify any subcontractors of the Ohio EPA requirements, have them sign affidavits that they understand those requirements, and furnish copies to the Franklin County Engineer's Office (FCEO) before their associated work begins.

Once the apparent low bidder has been determined in writing in the form of a letter from the Franklin County Engineer, the Contractor shall submit a Storm Water Pollution Prevention Plan (SWP3) within 15 working days for approval by FCEO. The SWP3 shall be prepared, stamped, and signed by a Professional Engineer experienced and competent in the design and implementation of standard erosion and sediment controls and storm water management practices addressing all phases of construction. The officer of the Contractor's company, who signs the NOI, as mentioned above, shall also sign the SWP3. Submit five half size sets and one electronic PDF set of plans for review to FCEO. FCEO will review/approve or review/return comments within 10 working days. If comments are returned to the Contractor, they shall be incorporated and resubmitted for approval within 5 working days. FCEO will back check the SWP3 within 5 working days and ask for additional changes or approve the SWP3.

The SWP3 shall incorporate at a minimum the following:

- "Part III, Section G SWP3 Requirements of the Ohio EPA, Authorization for Storm Water Discharge Associated with Construction Activity under National Pollutant Discharge Elimination System (NPDES)."
• Current edition of ODNr's Rainwater & Land Development Manual.
• Detailed description and drawings of all Best Management Practices (BMP's) including plan views, section views, legend, and installation practices the Contractor plans to use.
• Procedure for self-reporting verbally and in writing to FCEO and OEPA when the contractor learns of actual or potential violations.
• Methods the contractor will use to train or inform all of the contractor's employees, subcontractors, and other persons affected by the SWP3 of the requirements of the plan including methods and techniques to be used to ensure implementation of the plan. As stated above, it is the Contractor's responsibility to notify any subcontractors of the Ohio EPA requirements, have them sign affidavits that they understand those requirements, and furnish copies to the Franklin County Engineer's Office (FCEO) before their associated work begins.
• Emergency contact information, the general permit number, a copy of the NOI (if required), and a copy of the approval letter from OEPA (if required).
• Listing of subcontractors and co-permittees.
• Schedule which describes the sequence of major earth moving construction operations; the implementation of erosion, sediment, and storm water management practices; and the removal of During Construction BMP's upon project completion.
• Locations of concrete truck washouts; construction entrances; material storage areas; solid, construction, and hazardous waste storage areas; vehicle maintenance and fueling areas; onsite overburden, borrow, and stockpile areas; stream, creek, or channel crossings; sediment and storm water management basins including their sediment settling volume and contributing drainage area; open burning locations; etc.
• Estimate of BMP's including type and quantities.
• Detailed dewatering plans.

Upon approval, submit five half size sets and one electronic PDF set of the SWP3 to FCEO. No commencement of construction will be allowed until the SWP3 has been approved. The co-permittee/Contractor shall inform FCEO in writing of all amended activities to the SWP3 whenever there is a change in design, construction, operation, or maintenance that has a significant effect on the potential for the discharge of pollutants to Ohio waters or if the SWP3 proves to be ineffective in achieving the general objectives of controlling pollutants in storm water. It is the responsibility of the co-permittee/Contractor to evaluate all sediment and erosion control activities to ensure that no turbid discharge is released to the waters of the State of Ohio. The co-permittee/Contractor shall update the SWP3's at his/her cost as construction progresses to reflect changing conditions and work areas.

The co-permittee/Contractor shall be fully responsible for all compliance activities for all areas outside of the designed FCEO construction site. These areas include locations where soils are stockpiled, excavated for the purpose of fill, or disposed of as fill outside of the work limits in the construction plans. The co-permittee/Contractor shall file an NOI with Ohio EPA regarding these off-project areas and furnish copies to FCEO.

The Contractor is responsible for self performing and documenting all 832 required SWP3 Inspection Reports, including weekly, monthly, and rain event inspections. The cost to perform this work is considered incidental to the 832 Erosion Control, APP Item. In addition, FCEO will closely monitor the implementation of the SWP3 with emphasis on construction and continued maintenance of BMP's. FCEO will provide the co-permittee/Contractor notice of any deficiencies found during required inspections as required by the general permit. The Contractor shall install a rain gauge close to the Field Office, as directed by the engineer. FCEO stipulates the co-permittee/Contractor to make repairs within 24 hours of notification of deficiencies. If the contractor fails to remedy unsatisfactory sediment control and dewatering practices within 24 hours after receipt of such notice, FCEO may invoke the provision of ODOT CMS Section 105.15, correct the problem areas, and deduct the entire cost of the correction from monies due or to become due the contractor on the contract. Failure of the contractor to take corrective measures may result in enforcement actions and penalties as provided by NPDES, federal, state, and local laws. Any fines for non-compliance will be passed onto the contractor.

DRAWING: P:\Plan_Review\FCEO_Standards\Design_Standards\General_Notes.dwg
January 24, 2025, 1:03pm

FRANKLIN COUNTY ENGINEER
DATE: 01/01/2025
DRAWN BY: ACK
CHECKED: JDH
GENERAL NOTES
8
20

DESIGNER NOTE:

These general notes are specific to Franklin County Engineer's Office (FCEO) Capital Improvement Projects (CIP) and shall be used as dictated by the project scope. These County required notes do not constitute a complete project note set. All other required General Notes shall be incorporated into the project plans as set forth in the Ohio Department of Transportation (ODOT) Location and Design Manual, Current Edition.

References made to Construction and Material Specifications shall be from the current edition of the ODOT CMS unless otherwise noted. Check all notes for references to standard drawings and make sure they are included in the Title Sheet Standard Drawing Table.

(cont.)

The Contractor shall submit to FCEO a description of the BMP's that will be employed prior to work beginning, and FCEO reserves the right to deny implementation of any BMP that is determined to be non-effective prior to or during construction activities.

The stipulations of ODOT SS 832 shall apply. The SWP3 for this project will not be Non-Performed and is required before construction can begin. If an SWP3 is required for off-project EDA, then it shall be furnished by the Contractor prior to off-project EDA at no cost to FCEO. Payment for all work associated with EROSION AND SEDIMENT CONTROL for on-project EDA shall follow ODOT SS 832 and will be paid for by FCEO based on field measurements. Work associated with erosion and sediment control for off-project EDA will not be paid for by FCEO.

The Contractor is hereby advised that stricter pollution control standards and enforcement have been imposed by the Ohio EPA since March 10, 2003 and with a revision in April 2018. Also, many private citizen environmental groups, who have been known to file civil legal actions, are present in the area and observe all construction operations. The pay items (silt fences, check dams, sediment basins, etc.) set-up in the contract shall be used to control silt pollution as shown in the plans, directed by the Engineer, and/or ordered by the Ohio EPA.

When a Contractor needs to dam any waterway for dewatering purposes, any dikes placed in the stream must be of clean non-erodible materials. Dams constructed of soil in the stream are not acceptable, even if the stream work area is cordoned off or by-passed. Dams in the stream shall be of durable bags filled with coarse granular sand or clean stone (such as #57 or #2) or other methods acceptable to the EPA that prevent pollution. The labor and material used to install bags of sand or stone for stream dewatering purposes shall be included in the bid price for COFFERDAMS AND EXCAVATION BRACING, AS PER PLAN.

The Contractor will be required to build sediment basins or use equal methods to detain and clean water to acceptable EPA standards before releasing the water back into the stream. Sediment basin(s) shall be detailed in the SWP3 and are a listed item within the Erosion Control pay item.

Stone used for check dams for dewatering purposes in the stream shall be the ROCK CHANNEL PROTECTION (RCP) contingency set-up in the Erosion Controls pay item, the #2 Stone contingency set-up in the Erosion Controls pay item, or a combination of the RCP and #2 Stone contingency. Payment using the RCP and/or the #2 Stone contingency shall be at the measured quantity at the unit bid price for these items.

It is preferred to use permanent erosion control items as shown in the plans to control construction pollution when possible.

All items are to be maintained as per ODOT SS 832. Requirements to maintain sediment and erosion control items will be STRICTLY ENFORCED.

EROSION CONTROL, AS PER PLAN

The disturbed earth area of XXXX Sq. Ft. as calculated within the construction limits is less than one (1) Acre. Therefore this project falls under the provision of the Ohio Department of Transportation (ODOT) Supplemental Specification 832, specifically 832.04 - Scenario E and does not require general permit authorization for storm water discharges associated with construction activity under the National Pollution Discharge Elimination System. A formal Storm Water Pollution Prevention Plan (SWPPP) is not required and a Notice of Intent (NOI) will not be filed with the Ohio Environmental Protection Agency (OEPA). It is the intent of the Franklin County Engineer in conjunction with the Contractor to act responsibly in protecting our natural resources. Therefore, inlet protection, silt fence, and a concrete wash out shall be utilized as directed by the Engineer and paid for under Item 832 Erosion Control, As Per Plan.

Note to Designer: For projects with an Earth Disturbed Area over one acre use the Item 832 Storm Water Pollution Plan note and for projects under one acre use the Erosion Control, As Per Plan note.

ITEM 653, TOPSOIL FURNISHED & PLACED, AS PER PLAN

Payment for ITEM 653, TOPSOIL FURNISHED AND PLACED, AS PER PLAN, shall be the unit price bid per cubic yard, and shall include any necessary excavation to place the topsoil and any incidentals necessary to complete the work. This material shall be pulverized topsoil meeting ODOT CMS 653.02 and manufactured at a processing plant. Onsite processing operations will not be allowed. Topsoil Furnished and Placed shall be measured by the number of cubic yards furnished after compaction. Topsoil shall be placed at a compacted 4" minimum depth.

An amount of CU YD of Item 653 Topsoil Furnished and Placed, As Per Plan has been calculated for the work stated in the note above.

ITEM 659 SEEDING AND MULCHING, AS PER PLAN and ITEM 659 WATER, AS PER PLAN

The Contractor shall maintain all seeded areas until the Engineer accepts a vigorous grass grown area. This includes protection of the area from wind and fire. The areas shall be watered every other day (rain or shine) for three weeks after seeding. Work for eroded areas due to no fault of the Contractor shall be performed as stated in the ODOT-CMS SECTION 659. No payment shall be made for ITEM 659, SEEDING AND MULCHING, AS PER PLAN unless all the watering applications specified herein are made and until the grass exhibits a vigorous growth. Only when all of the above criteria are met, will payment be made for ITEM 659, SEEDING AND MULCHING, AS PER PLAN. All watering costs to be paid under the ITEM 659, WATER, AS PER PLAN.

Seed certification of grass seed shall be provided by seed vendor for each grass-seed mixture stating the botanical and common name, percentage by weight of each species and variety; and percentage of purity, germination, and weed seed. Include the year of production and date of packaging. Furnish National Turfgrass Evaluation Program (NTEP) data for each species to be used. A NTEP score of 6.0 or higher should be used for all turf tall fescue, a NTEP score of 5.8 or higher should be used for all Kentucky Blue Grass and a NTEP score of 6.0 or higher should be used for Perennial Ryegrass.

Grass seed must be fresh, clean, dry, new-crop seed complying with the A.O.S.A. "Journal of Seed Technology" rules for testing seeds for purity and germination tolerances.

Seed species shall be as follows, with not less than 90 percent germination, not less than 90 percent pure seed, and not more than 0.5 percent weed seed. For Kentucky Blue Grass a germination of, not less than 85 percent. The seed used should be a proprietary cultivar of a turf seed producer.

An example of a proprietary cultivar turfgrass seed mix proportioned by weight:

- A. ~75.0% Dixie Green 3 Seed Tall Fescue Mix
B. ~12.5% Argyle Kentucky Blue Grass
C. ~12.5% Banfield Perennial Ryegrass

All proprietary cultivar turfgrass seed mixes shall be approved by the Engineer before seeding and mulching takes place.

SEEDING. Sow seed at a total rate of 7-9 lb. / 1,000 S.F. with a spreader or seeding machine. Rake seed lightly into top 1/8 inch of soil, roll lightly, and water with fine spray.

HYDRO-MULCHING. The use of hydro-mulch (seeding, fertilizer, mulch, and water together) applications may be used at the rate as per ODOT-CMS 659 at no additional cost to the County. The contractor is totally responsible to ensure vigorous growth of the hydro-mulch at his/her own expense.

TURF MAINTENANCE. Maintain and establish turf by watering, fertilizing, weeding, mowing, trimming, and replanting to establish healthy, viable turf. Roll, regrade, and replant bare or eroded areas and remulch to produce a uniformly smooth turf. Provide the same materials and installation as those used in the original installation.

Mow turfgrass seed mix areas as soon as top growth is tall enough to cut. REPEAT Mowing to maintain specified height without cutting more than 1/3 of grass height. Mow areas to a height of 2 to 3 inches.

Note to Designer: For a multi-year project, add a mowing pay item.

The contractor shall plant Crown Vetch seed meeting ODOT 659.09 Class 3C and at the specified weight per area in Table 659.09-1 on slopes steeper than 3:1, instead of the above seed mix, as shown in the cross sections as directed by the Engineer.

ITEM 204 - PROOF ROLLING, AS PER PLAN

Portions of this roadway may be constructed on poorly drained soils. All prepared subgrades shall be proof rolled with a tandem wheel truck loaded with a maximum legal load while in the presence of the engineer who will determine the number of passes required. An estimated quantity for this item has been included in the general summary for use as directed by the engineer.

204 Proof Rolling X Hours

Note to Designer: For full roadway closures with full depth pavement construction, the Contractor shall use cement stabilization to stabilize the subgrade. For projects where traffic is maintained, include a 10% contingency (based on the project's overall subgrade area) for Unsuitable Soils.

UNSUITABLE SOILS

To account for any unsuitable soils identified during construction, a contingency quantity has been added to the plan to be used as directed by the engineer.

The contractor shall remove the unsuitable materials or soft soils and replace them with Geotextile Fabric, Geogrid, #2 stone, and 304 aggregate as noted in the sketch below. This work shall consist of removal of unsuitable material, placing geotextile fabric, furnishing, placing, and compacting the #2 stone and 304 aggregate in place. The aggregate shall meet the requirements of 703.01 and 703.04.

The aggregate base shall be placed in accordance with the requirements of pertinent parts of ITEM 304, except that when vibratory equipment is used for compaction, the compacted depth of single layer shall not exceed 12 inches.

If requested by the engineer, Geotextile Fabric shall be Type D. The material shall be placed according to the manufacturer's requirements and then overlaid with 12 inches of #2 stone.

If requested by the engineer, Geogrid shall be sized for #2 Stone and shall meet ODOT 712.15. The material shall be placed according to the manufacturer's requirements and then overlaid with 12 inches of #2 stone.

Material placement, depths and thicknesses shall be as directed by the engineer.

The following contingency quantities have been included in the General Summary to be used as directed by the engineer:

Table with 2 columns: Item Description and Unit/Quantity. Items include EXCAVATION OF SUBGRADE, GEOTEXTILE FABRIC, EMBANKMENT USING #2 STONE, EMBANKMENT USING ITEM 304, and GEOGRID FOR SUBBASE STABILIZATION.

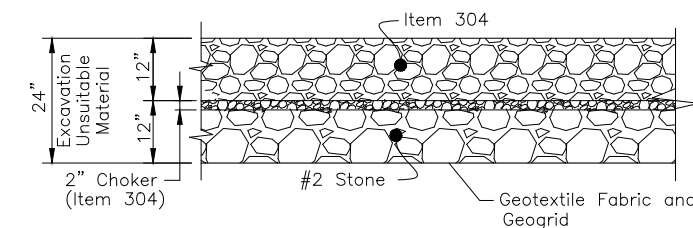

Note to Designer: Calculate undercut quantities over 25% of the subgrade area at a depth of 24 inches.

CONTAMINATED SOILS NOTE

There is a potential of encountering petroleum contaminated materials during excavations for construction activities. The estimated quantities have been included in the General Summary for this work. All excavations at the aforementioned locations shall be paid for under the plan bid items.

All potentially contaminated excavated materials may be stockpiled in an area provided by the contractor and approved by the engineer. The engineer may permit temporary storage of the suspected contaminated soils on an impermeable membrane. The membrane will be surrounded by bales of straw to prevent the suspected soils from coming in contact with the original soils. An impermeable membrane will be placed over the stockpile to prevent contact with precipitation and/or surface run-off. As a temporary storage alternative, the engineer may permit the contractor to direct load the excavated soils into trucks. Or as a third alternative, the contractor may place the material in leak-proof, covered containers provided by the contractor. The material will remain on-site until analytical results are received by the engineer.

This material will be properly tested (for disposal), transported, and disposed of in a licensed (by the local Health Department) and permitted (by the Ohio Environmental Protection Agency) solid waste facility. All material excavated by the contractor during installation of underdrains, storm sewers, and roadway construction within the aforementioned limits shall be subject to testing by a qualified inspector provided by the Franklin County Engineer. The inspector will field-screen material as it is excavated for potential petroleum contamination using an organic vapor analyzer (OVA).

Based on the OVA screening the inspector may direct the contractor to stockpile the material for further testing. All air monitoring instruments, sampling, and analyses of soils will be provided by the Franklin County Engineer, and are not to be included in the bid item. The analytical results will be used to determine how the stockpiled material may be used or disposed of as follows:

- The stockpiled material may be determined to be noncontaminated. Therefore, the material may be utilized for backfill/embankment if it meets ODOT and Franklin County Engineer's Specifications for backfill/embankment.
The stockpiled material may be determined to be a solid waste or petroleum contaminated material. The engineer will provide the contractor with copies of all analytical data for contaminated soils, and the contractor shall be responsible to obtain all necessary permits and approvals, and transport the material to an approved facility for proper disposal.

(cont.)

DESIGNER NOTE:

These general notes are specific to Franklin County Engineers Office (FCEO) Capital Improvement Projects (CIP) and shall be used as dictated by the project scope. These County required notes do not constitute a complete project note set. All other required General Notes shall be incorporated into the project plans as set forth in the Ohio Department of Transportation (ODOT) Location and Design Manual, Current Edition.

References made to Construction and Material Specifications shall be from the current edition of the ODOT CMS unless otherwise noted. Check all notes for references to standard drawings and make sure they are included in the Title Sheet Standard Drawing Table.

(con'd)

All transport vehicles for the movement of contaminated soils shall meet applicable local and state requirements for vehicles used for this purpose. The contractor shall maintain records (such as daily logs, landfill tickets, etc.) to document the source, movement, and destination of each truckload of contaminated soil. One copy of these records will be submitted to the engineer.

All excavated areas will be backfilled with suitable material in accordance with the project plans, applicable ODOT and Franklin County Engineer Specifications, and as directed by the engineer.

The contractor shall include the following in the unit price bid for ITEM SPEC, WORK INVOLVING PETROLEUM CONTAMINATED SOIL [TON]:

- All equipment and labor to acceptably handle the excavated material and stockpile it for further testing in a lab.
- If lab testing confirms contamination, all costs and fees for proper transportation and disposal at a state-certified solid waste/petroleum-contaminated soil facility. Payment will be based on ticket totals from the state-certified solid waste/petroleum-contaminated soil facility.
- If lab testing confirms non-contamination, all costs to remove the stockpiles. The material can then be reused as backfill onsite, if it meets the applicable ODOT and Franklin County Engineer Specifications, or hauled off the project. Payment will be based on field measurement of the stockpile with a conversion factor of 1.5 tons/CY.

Regulated Water

If excavations within the aforementioned limits require dewatering for construction purposes, the contractor will dewater, containerize, test the water (for disposal), and dispose of by methods approved by the engineer. The contractor will obtain all the required permits and/or authorizations needed to store, transport, and dispose of the water in accordance with applicable local, state, or federal regulations.

Low Strength Mortar Backfill

The storm sewer bedding and backfill shall be Item 613, LOW STRENGTH MORTAR (LSM). The intent will be to prevent potentially contaminated water from migrating along the pipe bedding and backfill. The LSM will extend from the bottom of the pipe trench to a level of one foot above the pipe. The LSM bedding and backfill will extend a minimum of ten (10) feet beyond the zone of suspected contamination in both directions.

Basis of Payment

The contractor will furnish all the labor, equipment, and materials necessary to properly handle, store, test (for disposal), transport, and disposal; including any required permits, approvals, or fees within the aforementioned location.

Payment for this work will be made at the contract price bid per TON, per GALLON, and per CUBIC YARD. The following estimated quantities have been included in the General Summary for the work noted above:

- Item SPECIAL, WORK INVOLVING PETROLEUM CONTAMINATED SOIL
- Item SPECIAL, WORK INVOLVING REGULATED WATER
- Item 613, LOW STRENGTH MORTAR BACKFILL

Phase II Report Environmental Site Assessment: The Phase II report may be obtained from the Franklin County Engineer's Office at 970 Dublin Rd; Columbus, OH 43215. The bidder is advised that this report is indicative of the type and condition of the subsurface at specific locations during the time the tests were taken. Subsurface conditions may vary with the seasons of the year, ground water table, etc. The bidder is therefore advised to conduct his/her own subsurface reconnaissance to gain a proper knowledge of the subsurface conditions and how construction operations will be affected accordingly. The contractor shall include his/her unit price bid for any and all bid items affected, the costs associated with subsurface material as described in this paragraph. The unit bid prices shall be full compensation for all items affected by excavated material.

Note to Designer: Include this note only if warranted.

STORM SEWER, WATERLINE & SANITARY SEWER BACKFILL

Trench backfill under all pavements (roadways, driveways, and sidewalks) and under influence lines of said pavements shall be Item 304 or No. 4 stone. Recycled 304 may be used as per ODOT CMS 703.11 where permissible for trench backfill only; recycled material cannot be used as 304 Aggregate Base. No 4 stone shall not be installed in lifts greater than 8". All pipe installations shall be inspected per ODOT Item 611.

Backfill shall be placed as follows:

The minimum trench width shall be 3' to allow room for mechanical compaction equipment: hoe tamps, jumping jacks, etc.

Provide compaction equipment that compacts the material under the haunch of the pipe. Use shovel slicing and spud bars in conjunction with the compaction operations to compact the material and to manipulate the material under the haunch of the pipe.

Item 304 shall be used as the granular material and shall extend up to the bottom of the roadway subgrade. Except as noted below.

Where the new storm sewer, waterline, or sanitary sewer crosses under an existing utility line, No. 57 Stone or No. 4 stone shall be used vertically from the bottom of the new trench to 6" above the top of the existing utility and horizontally 5' on each side of the existing utility (10' total).

The granular backfill shall be placed and compacted in lifts not to exceed 8" for 304 and 24" for No. 57 Stone.

Watering devices shall be onsite and used on 304 that has moisture content below optimum, as directed by the backfill inspector.

For trenches deeper than 10' use No. 4 stone in the bottom of the trench to a point such that the compacted granular backfill the rest of the way up is no deeper than 10'. See detail "A".

All costs for ITEM 304, NO. 57 STONE, and No. 4 stone backfill shall be included in the unit bid prices of the associated pipe.

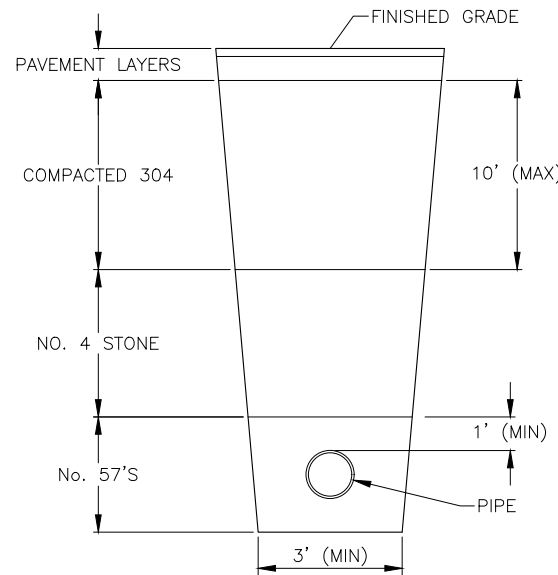

DETAIL "A" TRENCHES GREATER THAN 10' DEEP
NOT TO SCALE

IN NO WAY DOES THIS DETAIL INTEND TO SUPERSEDE OR NEGATE GOOD CONSTRUCTION PRACTICE.

Note to Designer: All pipe under pavements (roadways, driveways, and sidewalks) shall be "As Per Plan" items. Include with this note the provided detail labeled "Detail A, Trenches Greater Than 10' Deep"

TRENCHES IN ROADWAYS

All pavement for trenches in roadways, where through traffic is being maintained, shall be replaced with 10" of 301 asphalt base or 451 Concrete (for projects where through traffic is maintained). All costs for this work shall be included in the unit bid prices for ITEM 614, BITUMINOUS CONCRETE FOR MAINTAINING TRAFFIC if itemized or ITEM 614, MAINTAINING TRAFFIC, AS PER PLAN if not separately itemized.

When multiple trenches require resurfacing the full width of the road, GlasGrid 8502 or Engineer approved equal is required at the sawcut edges of the trench with 2.5' overlap on either side of the sawcut.

OVERNIGHT TRENCH CLOSING

Should work require that trenches remain open during non-work hours, the contractor shall use stone wedges and PCB per SCD MT-101.90 and MT 101.70 accordingly. When the pavement is removed and the contractor is unable to complete the required replacement in time for it to be opened to traffic as indicated in the specifications, the excavation shall be filled with a bituminous patch material with a durable surface or properly plated (as per City of Columbus standard drawing 1441, sheet 7). The contractor will be required to maintain these patches while they are in service. The cost of placing, maintaining, removing and disposing of the temporary patches or plates will be at the contractor's expense.

COLUMBUS WATERLINE WORK AND COMPACTED TRENCH BACKFILL

The Contractor is responsible for contacting the affected city water departments before any shutdowns or tie-ins of waterlines at least 48 hours before the work begins, not including Saturdays, Sundays, or legal holidays. The water departments may dictate the time of shutdowns, which may include shutdowns at night or on weekends. The Contractor is expected to cooperate with the water departments in physically passing out standard city approved fliers to affected city water customers. The Contractor shall use a map provided by the city showing customers affected. When passing out fliers, the Contractor is responsible for producing enough copies of the fliers to cover the shutdown area. All waterlines located within pavement area and less than 10' deep shall be backfilled with crushed aggregate meeting the requirements of Item 304, Aggregate Base, and shall be placed and compacted as set forth under 801.11 of the City of Columbus CMS. The backfill shall extend from the bottom of the trench to the pavement subgrade. The cost of the compacted backfill shall be included in the unit price bid for the waterline items in the contract. Waterlines located within pavement (or the influence line of pavement) and deeper than 10' shall be backfilled with LSMBF up to a point such that the compacted granular backfill the rest of the way up is no deeper than 10'. See detail "A".

Note to Designer: Use this note on all projects that have involvement with City of Columbus Waterlines.

ITEM 611 - TYPE C CONDUIT, AS PER PLAN

Where conduit runs are specified as Type C in the plans and these specific conduits run under an existing or proposed drive or under pavements within right-of-way lines, the backfill requirements shall be constructed as shown in the detail on this sheet. Compacted Granular Backfill conforming to Item 703.11 shall be installed to the lines established in the detail. The remaining backfill shall be as called out in Type C conduit in 611.06. All costs associated with the performance of this item shall be in the price bid for: ITEM 611 TYPE C CONDUIT, AS PER PLAN

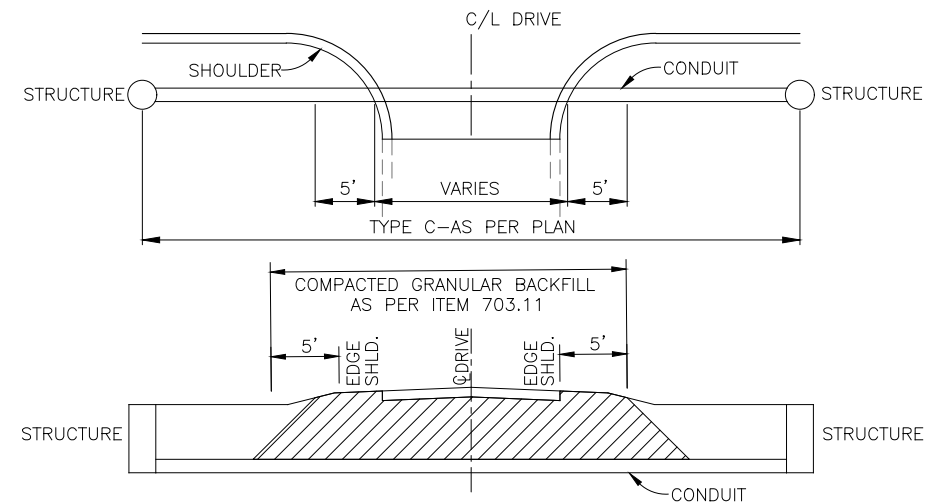

BACKFILL DETAIL - TYPE C CONDUIT, AS PER PLAN

ITEM 609 CURB, TYPE 6, AS PER PLAN

All curbing for this project shall conform to Item 609 of the current ODOT CMS and to Standard Drawing BP 5.1, except as detailed on the typical section page.

Note to Designer: Use this note on all county projects that require Item 609 Combination Curb and Gutter, Type 6, As Per Plan. Include the curb detail provided on the Typical Sections.

DESIGNER NOTE:

These general notes are specific to Franklin County Engineers Office (FCEO) Capital Improvement Projects (CIP) and shall be used as dictated by the project scope. These County required notes do not constitute a complete project note set. All other required General Notes shall be incorporated into the project plans as set forth in the Ohio Department of Transportation (ODOT) Location and Design Manual, Current Edition.

References made to Construction and Material Specifications shall be from the current edition of the ODOT CMS unless otherwise noted. Check all notes for references to standard drawings and make sure they are included in the Title Sheet Standard Drawing Table.

ITEM 609 COMBINATION CURB & GUTTER, TYPE 2, AS PER PLAN

All curbing for this project shall conform to Item 609 of the current ODOT CMS and to Standard Drawing FCEO RD-06. Where curb crosses driveway "curb cut" areas the contractor shall use a medium set CLASS MS CONCRETE (CMS 499.03, which refers to Supplement 1126) as directed by the Engineer.

Note to Designer: Use this note on all county projects that require Item 609 Curbing. Quantity calculations for curb using MS Concrete should conform to the criteria of this note and be clearly shown on a driveway detail sub-summary table. Use only one pay item for both Class C Curb & Gutter and Class M.S. Curb and Gutter.

8" REINFORCED CONCRETE PAVEMENT

The truck apron shall be stamped with "Arizona Flagstone" utilizing Scofield color C3150, "Bark" or an approved equal pattern and color system. The stamped concrete shall conform to ODOT CMS 451 and all applicable manufacturer's requirements. A sample of the pattern and color shall be provided to and approved by the Franklin County Engineer prior to construction. All materials, labor, equipment, and other expenses associated with stamping and coloring the concrete shall be included in the unit price bid for ITEM 451, 8" REINFORCED CONCRETE PAVEMENT, AS PER PLAN & PROPOSAL NOTE.

EXISTING/UNIDENTIFIED STORM SEWERS

If any existing storm sewers or field tiles are encountered during construction, leave exposed and contact the Franklin County Drainage Engineer's office at (614) 525-5138 to have the existing tile size, composition, horizontal location, and flowline recorded in the asbuilt plan. Contractor to provide northing and easting for all storm sewers or field tiles.

DRAINAGE CONNECTIONS

All conduits paid for under this item shall be considered and bid as an "As Per Plan" item. See note below.

All drains, which are encountered during construction, shall be provided with unobstructed outlets. Existing drains which are located below the roadway ditch elevation, and which cross the roadway, shall be replaced within construction limits using Item 611 Conduit, Type B, one commercial size larger than the existing conduit.

Existing collectors and isolated farm drains, which are encountered above the elevation of roadway ditches, shall be outletted into the roadway ditch by Item 611 Type C Conduit. The optimum outlet elevation shall be 12" above the flow line elevation of the ditch.

The location, type, size and grade of replacements shall be determined by the Engineer and payment shall be made on final measurements.

Tie-ins to existing conduits shall use a rubber boot connection and hardware as approved by the Engineer. All conduits shall be Schedule 40 Polyvinyl Chloride Plastic Pipe (PVC). Blind tap connections and cutting into curb or drainage structures shall be included in the linear foot price bid for each item.

Erosion control pads and animal guards shall be provided at the outlet end of all drains as per Standard Construction Drawing DM-1.1M, except when they outlet into a drainage structure. Payment for the erosion control pads and animal guards shall be included for payment in the pertinent conduit items.

The following estimated quantities have been included in the General Summary for the work noted above

ITEM 611	4" CONDUIT, TYPE B, SCHEDULE 40 PVC, AS PER PLAN	50 LIN FT
ITEM 611	6" CONDUIT, TYPE B, SCHEDULE 40 PVC, AS PER PLAN	50 LIN FT
ITEM 611	8" CONDUIT, TYPE B, SCHEDULE 40 PVC, AS PER PLAN	50 LIN FT
ITEM 611	4" CONDUIT, TYPE C, SCHEDULE 40 PVC, AS PER PLAN	50 LIN FT
ITEM 611	6" CONDUIT, TYPE C, SCHEDULE 40 PVC, AS PER PLAN	50 LIN FT
ITEM 611	8" CONDUIT, TYPE C, SCHEDULE 40 PVC, AS PER PLAN	50 LIN FT
ITEM 611	INSPECTION WELL	2 EACH

Necessary bends, branches and rubber boot connectors shall be included in the price bid for each item.

The Contractor shall not order any of the above materials unless approved by the Engineer.

Note to Designer: Quantities shall be based on criteria determined by the Franklin County Highway Design Engineer. Use 100 Lin Ft per item as a minimum and keep Contingency quantities for Farm Drains to 100ft or less so inspection per 611 is waived.

TREATED SEPTIC CONNECTIONS

Treated septic flow may be discharged into the highway drainage system provided the owner has secured the approval of the Franklin County Health Authorities and has acquired the official permit to have the connection made.

In each case, where a permit has been issued for making a treated septic connection into the highway drainage conduit, an Inspection Well shall be provided in accordance with the detail shown on Standard Drawing DM-3.1.

The following estimated quantities have been included in the General Summary for use as directed by the Engineer, in making the above connections.

ITEM 611,	6" CONDUIT, TYPE C, SCHEDULE 40 PVC, AS PER PLAN	___ LIN FT
ITEM 611,	INSPECTION WELL*	___ EACH

Necessary bends and branches shall be included for payment in the pertinent conduit item.

Tie-ins to existing conduits shall use a rubber boot connection and hardware as approved by the Engineer. Blind tap connections and cutting into curb or drainage structures shall be included in the linear foot price bid for each item. All blind tap connections require installation of inspection wells. Inspection wells are required for all blind taps.

The Contractor shall not order any of the above material until authorized by the Engineer.

*No Inspection Well is required if effluent is discharged into a catch basin or manhole.

UNTREATED SEPTIC CONNECTIONS

This plan makes no provision for connecting, nor shall the Engineer or contractor connect, any untreated septic drainage into the highway drainage system. Any pipe possibly carrying untreated septic flow shall be left exposed. Call Franklin County Health Dept. at (614) 525-3909 and the Franklin County Drainage Engineer's Office at (614) 525-5138 or (614) 525-2787 for direction on whether or not to tie the pipe into the highway drainage system or plug the pipe at R/W line w/ Class C concrete. Payment for plugging shall be included in contract price for the pertinent 202 or 203 item.

ITEM 202, DRILLED WATER WELL ABANDONED

The water well(s) listed in the plans shall be abandoned by the roadway contractor. FCEO will obtain the required permit(s) from ODNr prior to construction. All material, labor, and equipment costs associated with abandoning the well(s) shall be included in the unit price bid for ITEM 202, DRILLED WATER WELL ABANDONED, [EACH]. Refer to the attached "State of Ohio Technical Guidance for Sealing Unused Wells."

ITEM 201, CLEARING AND GRUBBING

All trees, fence posts, rocks, brush, stumps and fence within the construction limits of this project shall be removed unless marked "Do Not Disturb". Unless itemized separately, all of these items shall be removed under the lump sum price bid for item 201, Clearing and Grubbing. Items within the construction limits that are marked "Do Not Disturb" or "DND" shall not be removed or damaged.

ITEM Special, Contingency

This item is a fixed amount for all bidders and is included in the Engineer's Estimate listed on the Bid Blank. It will be utilized for unforeseen conditions and extras encountered during the course of construction. Use of any portion of this item must be approved in writing by the Franklin County Engineer, Chief Deputy Engineer, and Construction Engineer.

CENTRAL OHIO TRANSIT AUTHORITY (COTA) COORDINATION

The designer shall consult COTA staff cotadesignreview@cota.com for any activities that affects COTA's current and future transit services such as bus stop installation or upgrades, residential and commercial developments along existing COTA routes, and new developments that will be served by transit.

Use COTA Bust stop Design Guide: <https://www.cota.com/wp-content/uploads/2016/04/Bus-Stop-Design-Standards.pdf>

NON-RUBBER TIRE VEHICLES

Non-rubber tired vehicles shall not be moved on or across public streets, highways, private roadways, or parking lots without the written permission of the Engineer.

EXISTING UTILITIES

The Identity and location of the existing underground facilities known to be located in the construction area have been shown on the plans as accurately as provided by the owner of the utility. Franklin County Engineers office and/or engineer assume no responsibility for the accuracy of the locations or depths of the facilities shown on the plan. The Contractor shall be responsible for coordinating the relocation and/or protection of any utilities as required by the plan, with the owner of the affected utility. Private utility manholes within the limits of the work shall be adjusted to grade by the respective utility.

The flow in all sewers, drains, field tiles, and watercourses encountered shall be maintained by the Contractor at their expense, and whenever such watercourses and drains are disturbed or destroyed during the construction of the work, they shall be restored by the Contractor at their own expense to a condition satisfactory to the engineer.

The Contractor is responsible for the investigation, support, protection, and restoration of all existing utilities and appurtenances whether shown on these plans or not. The Contractor shall expose all utilities or structures prior to construction to verify the vertical and horizontal effects on the proposed construction. Prior to any excavation, the Contractor shall contact OHIO811 to obtain an excavation ticket. A 48-hour notice shall be given to owners of underground utilities shown on the plans who are not members of a registered underground protection service. Listed below are utility companies that have facilities located within the work limits of this project and subscribe to OHIO811:

DRAWN BY ACK	CHECKED JDH	GENERAL NOTES
DATE 01/01/2025		
FRANKLIN COUNTY ENGINEER		11 20

ITEM 614 MAINTAINING TRAFFIC, AS PER PLAN

Note to Designer/Reviewer: (Typical Lane Closure for two-lane roadway)

A minimum of two 10' lanes (one lane of traffic in each direction) shall be maintained on all roads during non-working hours and peak periods (7am-9am and 4pm-6pm). Two-way one lane traffic is permitted during working non-peak hours (9am-4pm) in accordance with ODOT Standard Construction Drawing MT-97.10 or MT-97.11, except that law enforcement officers (L.E.O.s) with patrol cars shall be substituted for each flagger. If this requirement cannot be met, traffic shall be detoured using ODOT Standard Construction Drawing MT-101.60 and OMUTCD Chapter 6H (Figure 6H-20).

Note to Designer/Reviewer: (Typical closing one or two lanes of a multi-lane roadway)

A minimum of two 10' lanes shall be maintained on all roads during non-working hours and peak periods (7am-9am and 4pm-6pm). (For Alum Creek Dr. 6am-9am and 2pm-6pm). A temporary closure of one of the two eastbound traffic lanes, to accommodate encroachment into the westbound traffic lane for driveway construction, is permitted during working non-peak hours (9am-4pm) (Alum Creek 9am-2pm). ODOT's Typical Application drawings TA-31 and TA-32 (OMUTCD Figures 6H-31 and 6H-32), as well as MT-95.30 through 32 shall be used as general guidance for the MOT set-up, as directed by the Engineer.

The Contractor may submit an alternate MOT plan at the preconstruction meeting showing how they plan to maintain traffic in accordance with the OMUTCD and these traffic maintenance notes. These plans will need to be reviewed and approved by the Franklin County Engineer's Office. The Contractor will be advised as to the review results in writing within thirty (30) days.

The Contractor shall notify the County Engineer's Mobility Department at 614-525-6036 two weeks prior to beginning work, and weekly thereafter, to discuss any changes to the maintenance of traffic plan and/or completion date. Before work is started on this project the Contractor shall submit a written schedule of operation and a traffic maintenance control plan for approval. No work will be started that will restrict any lane usage unless it is the intent of the Contractor to work full time with a full force in order to complete the work without unnecessary delays.

The following is the suggested sequence of construction for this project:

Note to Designer/Reviewer: (Insert detailed description of MOT here. Any project requiring a detour shall include a description as provided. Typical lane closures or projects without multiple phases do not need to provide a sequence, unless required by the Engineer.)

(Sample closure/detour description provided below.)

All construction shall be performed in one phase. All lanes of Morse Road and Kitzmiller Road shall be closed in both directions of construction. The following detour routes shall be used during construction and are detailed on sheet XX:

Eastbound Morse Road traffic shall be detoured northbound on Reynoldsburg-New Albany Road to eastbound East Dublin-Granville Road to southbound Babbitt Road and rejoin Morse Road eastbound at its intersection with Babbitt Road.

Westbound Morse Road traffic shall be detoured southbound on Babbitt Road to westbound Clark State Road to northbound Reynoldsburg-New Albany Road and rejoin westbound Morse Road at its intersection with Reynoldsburg-New Albany Road.

Northbound Kitzmiller Road traffic shall be detoured northbound on Reynoldsburg-New Albany Road to eastbound East Dublin-Granville Road and rejoin northbound Kitzmiller Road at its intersection with East Dublin-Granville Road.

Southbound Kitzmiller Road traffic shall be detoured westbound on East Dublin-Granville Road to southbound Reynoldsburg-New Albany Road and rejoin southbound Kitzmiller Road at its intersection with Reynoldsburg-New Albany Road.

The following devices must meet NCHRP 350 or MASH-08 before the devices are installed on the project: drums, cones, vertical panels and the panel support, portable sign supports, temporary impact attenuators, temporary concrete barrier, and barricades.

All construction signing shall be installed and covered before construction begins. After construction sign installation, the Contractor shall notify the Franklin County Engineer's Office Mobility Department at 614-525-6036 three (3) working days before work begins and request an inspection of all signing.

Faces of construction signs and reflective sheeting on barricades shall be Type H (VIP). All orange construction signs shall be fluorescent orange. All sheeting will be tested for reflectivity per ODOT 730.192. Vertical panels and drum bands shall be reflectorized with Type G (high intensity) sheeting complying with the requirements of 730.19. All signs and barricades, vertical panels, and drums will be like new and in good condition in conformance with "Quality Guidelines for Temporary Traffic Control Devices and Features" published by ATSSA.

Maintenance of all Contractor-supplied signs, barricades, vertical panels and drums is the Contractor's responsibility. If the Contractor fails to correct deficiencies within four (4) hours of notification, Franklin County shall correct or hire someone to correct the deficiencies. The Contractor shall then be back charged per ODOT Specification 614. In the case that back charging the Contractor is not applicable, the County will rescind and withhold all permits issued to the Contractor to work within County right-of-way until the issue is settled. These provisions shall not in any way relieve the Contractor of any of their legal responsibilities or liabilities for the safety of the public.

All barricades at closures shall have yellow Type A low intensity flashing warning lights and two flags. Reflective material is required on both sides of all barricades.

Cones are approved for daytime use only. Drums shall be used at night and have yellow Type C steady burn lights. Cones and Drums shall be placed as follows: 25' c/c on tangents, 15' c/c on tapers, and 8' c/c in radii.

All signs nine square feet (36" x 36") and over shall have yellow Type A low intensity flashing warning lights and two flags.

ITEM 614 MAINTAINING TRAFFIC, AS PER PLAN CONTINUED

All work and traffic control devices shall be in accordance with ODOT CMS 614 and other applicable portions of the specifications, as well as the latest version of the OMUTCD. Payment for all labor, equipment and materials shall be included in the lump sum contract price for Item 614, Maintaining Traffic, as Per Plan, unless separately itemized in the plan.

COORDINATION WITH COTA

The Contractor shall notify the COTA Senior Service Planner, of all traffic restrictions and upcoming maintenance of traffic changes on a weekly basis. When detours are planned, the notification shall be reported at least 30 days in advance of any road closures. Lane closures of less than two weeks duration and more than two days shall be reported at least 3 working days in advance. For short-term lane closures (2 days or less) notification shall be made at least one day in advance. The report shall be of a format approved by the Project Engineer or one supplied by the Senior Mobility Technician. COTA can be reached by phone at 614-308-4373, or by email at evanspm1@cota.com.

To coordinate area transit service including routing and stop impacts and/or MOT impacts contact Paul Evans, COTA ROW Operations Manager, at evanspm1@cota.com or at 614-308-4373 14 days prior to occurrence.

(Projects in the Rickenbacker Area shall include notification of the GREAT Workforce Transportation Director: Bob Dowler at (614)836-7433 ext. 2 or by email at bdowler@groveport.org

Note to Designer/Reviewer: (Use the following note for projects with multi-phase MOT set-ups.)

ITEM 614 - LAW ENFORCEMENT OFFICER (WITH PATROL CAR), AS PER PLAN In addition to the requirements of ODOT CMS 614, the OMUTCD, and ODOT SCD MT-97.10 and MT-97.11, a uniformed law enforcement officer (L.E.O.) and official patrol car with working top mounted emergency flashing lights, shall be provided for the following tasks:

1. For controlling the detour of traffic during the entire advance preparation and closure sequence where complete blockage of traffic is required. On the day the intersection is closed, and for a minimum of two days thereafter, or as directed by the Engineer, one L.E.O. with patrol car shall be posted at each detour point from 7:00 am to 6:00 pm to ensure that only work zone area residents use the closed roadway.
2. For all lane closures. L.E.O.s shall be used where the OMUTCD intends that flaggers be used.
3. During a traffic signal installation.
4. Work within a signalized intersection, defined as the area bounded by the rear crosswalk lines (or far stop bars if there are no crosswalks).

The L.E.O.s are considered to be employed by the Contractor, and the Contractor shall be responsible for their actions. Although they are employed by the Contractor, the Engineer shall have control of their placement. The official patrol car shall be a public safety vehicle as required by the Ohio Revised Code. L.E.O.s shall contact the Engineer's First Responder Liaison at 614-525-3054 at least 48 hours before starting any work under this item.

All work described above shall be paid for under the following Bid Item:
Item 614 - Law Enforcement Officer (with patrol car), As Per Plan xx Hours

Payment for L.E.O.s used for flagging operations, other than as outlined above, shall not be made under this item, but shall be included in the cost of the bid item for which the flagging is being conducted.

MAINTENANCE OF TRAFFIC SIGNAL INSTALLATION

The Contractor shall be responsible for operating and maintaining all existing & proposed traffic signal devices under the following conditions from the time of award of the project until the device has been accepted by the Franklin County Engineer's Office.

The Contractor shall provide two or more contact persons who can receive all device out-of-service calls that fall under the Contractor's responsibility. The Contractor shall dispatch maintenance personnel to correct the problem. The Contractor shall provide the Franklin County Engineer & the Project Engineer with addresses & phone numbers of these contact persons. Maintenance personnel may be used to perform other duties as long as prompt attention is given to these calls & a person is continuously available twenty-four (24) hours a day & seven (7) days a week. The Contractor shall provide maintenance service entirely with their personnel.

The Contractor shall correct all LED outages, device malfunctions of any type, internal cabinet power losses, span or cable problems, and misaligned or damaged vehicular or pedestrian signal heads within two (2) hours after the Contractor's contact person has been notified of any one of the above. In the event a new signal device is damaged prior to acceptance, the damaged device except poles shall be replaced or repaired by the Contractor to the satisfaction of the Franklin County Engineer's Office. Any damaged cabinet assembly device if repaired shall be tested once again by Franklin County before the device can be installed.

In the event of a loss of power to the signal indications other than an electric company general power outage, the Contractor at their expense shall immediately take action (within 30 minutes) to properly erect temporary stop sign(s) & provide police officer(s) to direct traffic until the signal is back on "flash" or operating properly.

If a traffic signal pole is damaged, and the damage causes pole instability, then the Contractor shall take immediate action (within 2 hours) to stabilize it. The Contractor shall still be responsible for providing the project with a new undamaged pole.

Where out-of-service calls are the direct result of a vehicular accident the response of the Contractor shall be as outlined above. The Contractor shall be responsible for the collection of any compensation from those parties responsible for the damage to the Contractor's materials.

Where the Contractor has failed to respond or cannot respond to an out-of-service call within the time period specified above at locations under their responsibility, the Franklin County Engineer may take action as it deems necessary to correct the situation. This action may include controlling the intersection using Franklin County law enforcement officers, completely removing or replacing any malfunctioning traffic control device(s), and/or installing any device(s) required to return the intersection to regular signal operation. All costs associated with these actions shall be billed directly to the Contractor & not included in item 614 maintaining traffic.

Any non-operating vehicular or pedestrian signal head or pushbutton shall be covered as referenced to in these plans. All signal heads while covered shall be dark by disconnecting power to the signal indications. No covered head shall block the view of an operating head. A minimum of two (2) vehicular signal heads per travelled direction (spaced 8' apart minimum and 12' maximum) shall be operating at all times. No exceptions!

Under Contractor Maintenance, it is the responsibility of the Contractor to mark underground electrical conduits/circuits requested by OUPS tickets. The Contractor shall mark any existing or newly installed underground conduits with paint and flags, within 24 hours of the direction of the Engineer.

All costs resulting from the above requirements, except as noted, shall be considered to be included in the lump sum bid price for Item 614 - Maintaining Traffic, As Per Plan.

DAMAGE TO VEHICLE DETECTORS

The Contractor shall repair or replace vehicle detector loops, detector lead-in cables, conduit, pull boxes, or related traffic signal equipment that is damaged by the Contractor. The Contractor, at the direction of the Project Engineer, will be required to install a video camera-based vehicle detection system to replace any damaged detectors within 48 hours. All repairs to such damaged vehicle detection systems shall be made within 21 days. The Contractor shall provide the Project Engineer a minimum of 7 days advance notice of any anticipated damage to vehicle detection systems, in order to document the type and location of the anticipated damaged equipment. The same conditions of repair or replacement apply to any accidentally damaged vehicle detection equipment. The following items shall be included in the Contractor's bid for damaged vehicle detection systems, as needed.

Item	Quant.	Unit	Description
625		Feet	Trench
625		Feet	Conduit, 2", 725.04
625		Each	Pull Box, 725.08, 13"x24"
632		Each	Detector Loop
632		Feet	Loop Detector Lead-In Cable
Special		Each	Video Detection System, As Per Plan

DRAWN BY: ACK, CHECKED: JDH, DATE: 01/01/2025, MAINTENANCE OF TRAFFIC NOTES, FRANKLIN COUNTY ENGINEER

DRAWING: P:\Plan_Review\FCEO_Standards\Design_Standards\General_Notes.dwg, January 24, 2025, 11:58pm

ITEM 816 VIDEO DETECTION SYSTEM, AS PER PLAN

This item shall consist of furnishing and installing Auto Scope Solo Pro II camera(s) or Iteris Versicam camera(s), or approved equal, including all labor, wiring, materials, and equipment necessary to provide a video detection system complete and in place. The system consists of each color camera with zoom lens and the machine vision processor (MVP) integrated into a single unit. The system shall be capable of each MVP controlling iris adjustment and lighting control individually. Twisted pair cable shall be used for transmitting processed video and data from the MVP to the signal controller cabinet. The interface to the signal controller shall be compliant with NEMA TS1 or TS2 standards. The video detection system cabinet hardware shall be capable of operating four video detection cameras. The system shall be fully compatible with TS1 or TS2 controllers and cabinets. Additionally, this item includes any adjustments necessary to ensure proper operation during each phase of MOT operations. A 30' bracket arm shall be provided, as needed, to support each proposed camera over the travelled lanes. The following quantity has been carried to the General Summary for this item.

Item 816, Video Detection System, As Per Plan 1 Each

EXISTING TRAFFIC SIGN MAINTENANCE

Special care shall be taken to maintain existing street name signs and stop signs. If necessary, the Contractor shall relocate these signs out of the way of construction, but in conformance with OMUTCD. Any damaged sign shall be replaced at the expense of the Contractor.

PERMANENT TRAFFIC CONTROL

All existing and proposed permanent traffic controls not in conflict with the temporary traffic controls shall be maintained throughout the project by the Contractor. The Contractor shall contact the Franklin County Engineer's Mobility Department at 614-525-6036 prior to disturbing or relocating any existing signing. The Contractor shall assume all liability for missing, damaged, and improperly placed traffic control devices.

LOCAL ACCESS

Ingress and egress shall be maintained to all residential and commercial properties. Driveway closures may be necessary to enable work on, or in front of, a drive. The Contractor will be responsible for notifying owners, residents, or business operators, in writing, at least 48 hours, but not more than 72 hours, prior to closure. The Engineer shall be given a list of the persons that were given notices with the date of notice included. Closure is permitted only during work hours and access must be returned at the end of each working day. Properties with multiple drives may have one drive closed at a time, while work is performed in the area of the closed drive.

Individual drive closures shall be kept to the minimum time needed for construction activities. Every effort must be made to accommodate both residential and commercial property owner's need for access.

PEDESTRIAN ACCESS

The Contractor shall be responsible for the protection and safe movement of pedestrians through, around, and away from the construction site. The safety of pedestrian traffic shall be considered at all times in the provision of traffic control devices required by these plans and notes. It shall be the Contractor's responsibility to provide lights, signs, barricades, and other warnings to physically separate the pedestrian from hazards incidental to the construction operations such as open excavations, etc. Traffic control for pedestrian movements shall be in accordance with OMUTCD Figure 6H-28 and 6H-29 (TA-28 and TA-29). Pedestrian MOT shall, at all times, be subject to the approval of the Engineer.

ITEM 614 PORTABLE CHANGEABLE MESSAGE SIGN, AS PER PLAN

The Contractor shall furnish, install, maintain, and remove portable changeable message sign(s) (PCMS) for the duration of the project. The signs shall be of a type approved by the County.

Each sign shall be trailer mounted and equipped with a functional dimming mechanism to adjust the brightness under varying light conditions and a tamper and vandal proof enclosure. Each sign shall have operation instructions to enable on-site operation and troubleshooting. The sign shall also be capable of being powered by an electrical service drop from a local utility company.

PCMS's shall be in place one (1) week prior to construction to advise the public. At least one (1) PCMS shall be located on each approach, in advance of the work area. Other PCMS's may be required in advance of detours. They shall be placed in a highly visible location, as approved by the Engineer, and protected from traffic. The Contractor shall, at the direction of the Engineer, relocate the PCMS to improve visibility or accommodate changed conditions. When not in use, the PCMS shall be off, facing away from all traffic and shall display one or more high intensity yellow reflective sheeting surfaces of 9-inch by 15-inch minimum size facing traffic.

The sign shall have the capability to store up to 99 messages. Message memory or pre-programmed displays shall not be lost as a result of power failures to the on board computer. The message sequence to be displayed for this project shall be shown in the Maintenance of Traffic Plan. The sign legend shall be capable of being changed in the field. The PCMS shall have a full matrix display with the ability to show multiple line formats with up to six message phases. The PCMS shall contain an accurate clock and programming logic which will allow the sign to be activated, deactivated or changed automatically at different times of the day for different days of the week.

The PCMS shall be maintained in good working order by the Contractor. Any failure shall not result in the sign being out of service for more than 12 hours including weekends. Failure to comply may result in an order to stop work and open all traffic lanes and/or to have the County take appropriate action to safely control traffic. Any costs accrued by the County will be deducted from moneys due, or to become due the Contractor on their contract.

The Contractor shall be responsible for 24 hours per day operation and maintenance of these signs on the project for the duration of the phases when the plan requires their use. The Contractor is responsible for changing messages within 2 hours following notification from the Engineer.

Payment for Item 614 Portable Changeable Message Sign, As Per Plan shall be made at the contract unit price bid per sign-month, and shall include all labor, materials, equipment, fuels, lubricating oils, software, hardware, and incidentals to perform the above described work.

The following quantity has been carried forward to the general summary:

Item 614 - Portable Changeable Message Sign, as per plan. XX Sign-Months

WORK ZONE RAISED PAVEMENT MARKERS

Work Zone Raised Pavement Markers (WZRPM) shall be placed on all work zone lines shown in the plans. Payments for the WZRPMs placement, replacement, removal, and relocation, including all labor and materials, shall be included in the contract price for Item 614, Maintaining Traffic, As Per Plan.

REMOVAL OF PAVEMENT MARKINGS

Removal of existing or work zone pavement markings from the final surface course using water blasting or grinding is not permitted. Removal of markings shall be by means of full-width milling and overlaying to a depth of 1 1/2" before the permanent markings are applied. All replacement pavement markings shall comply with ODOT Item 644 - Thermoplastic Pavement Marking, applied at the widths shown below:

- Edge Lines - 6" White
- Channelizing Lines - 12" White
- Center Lines - 6" Yellow

ITEM 614--SOLAR POWERED RADAR SPEED FEEDBACK SIGN

The Contractor shall be responsible for obtaining and installing solar powered radar speed feedback signs during the closure of road name. the signs shall be mounted below existing speed limit signs.

At the completion of the project the speed feedback signs shall be removed and delivered to the mobility department at FCEO's office.

Placement of the feedback signs is to be shown on the Maintenance of Traffic detour route, or as directed by the Engineer.

Payment shall be full compensation for all material, labor, incidentals and equipment necessary for furnishing, installing, maintaining and delivering each item. the following quantities have been carried to the general summary;

ITEM 614--SOLAR POWERED RADAR SPEED FEEDBACK SIGN EACH

ITEM 410--TRAFFIC COMPACTED SURFACE

The Contractor shall furnish and apply traffic compacted surface as directed by the Engineer. The Contractor shall remove the compacted surface as directed by the Engineer. The following estimated quantities have been included for maintaining traffic during construction:

ITEM 410--TRAFFIC COMPACTED SURFACE, TYPE A CY

ITEM 616--DUST CONTROL

The Contractor shall furnish and apply water for dust control as directed by the Engineer. the following estimated quantities have been included for dust control purposes:

ITEM 616--WATER GAL

MAINTENANCE OF TRAFFIC NOTES

FRANKLIN COUNTY ENGINEER

STREET LIGHTING NOTES

The street lighting shall be constructed in accordance with the current City of Columbus, Ohio "Construction and Material Specifications" (CMSC), (2018 Edition, Section 1000, titled "Street Lighting"), including all supplements thereto, in force on the date of the contract. CMSC shall govern all materials and workmanship involved in the improvements shown on these plans, except as such specifications are modified by the following or by the specifications details set forth herein.

The Columbus Division of Power (DOP) Material and Installation Specifications (MIS) are hereby incorporated into this set of plans. The Division of Power standard specifications can be obtained at 3500 Indianola Avenue. The MIS numbers are listed in the roadway lighting quantities are reference to specific specifications published by the Division of Power which shall govern all work relating to the installation of roadway lighting equipment and apparatus for this project.

The plan details shall be considered supplemental to City of Columbus Material and Installation Specifications (MIS).

The Contractor is responsible to comply with all local codes and ordinances pertinent to the progression on the work described with the project plans. Any required permits shall be obtained and paid for by the Contractor. The Contractor and/or Subcontractor shall be responsible for complying with all Federal, State, and Local, safety requirements, together with exercising precautions at all times for the protection of persons (including employees) and property. It is also the sole responsibility of the Contractor and/or Subcontractor to initiate, maintain, and supervise, all safety requirements, precautions, and programs, in connection with the work.

As-built record - The Contractor shall maintain a set of project record documents. These documents shall include reviewed shop drawings, change orders, equipment operating instructions, field test records, and as-built drawings. The as-built drawings shall be marked legibly in red with the actual location of equipment as constructed.

All equipment installed shall have locations marked in distances off a landmark at least every 25 feet or location at a later date. Final documents and plans shall be handed over to the Franklin County Engineer's Office.

All items of work called for in the plans, for which no specific method of payment is provided, shall be performed by the Contractor and the cost of these shall be included in the unit price bid for the various related items. This includes, but is not limited to, such incidental items as relocation of mail boxes, saw cutting, and removal and/or relocation of signs, railroad ties, sprinklers, relocations roof or sump drains around light pole foundations, hand digging around underground utilities, or other miscellaneous items.

The following is a list of all City of Columbus MIS applicable to this project:

- MIS-001 MIS-201
- MIS-002 MIS-305
- MIS-003 MIS-403
- MIS-004 MIS-602
- MIS-054 MIS-700
- MIS-055 MIS-801
- MIS-056

UTILITIES NOTIFICATION

At least two (2) working days prior to commencing construction operations in any area which may involve underground facilities, the Contractor shall be REQUIRED to notify the Project Engineer, the registered utility protection services (OUPS 1-800-362-2764) and the owners of all underground facilities shown in the plans.

After notice is received, the owner of any underground utility facility that is to remain in service during and/or after construction shall within forty-eight (48) hours, excluding Saturdays, Sundays, and legal holidays, stake, mark, or otherwise designate, the location of underground facilities in the construction area in such a manner as to indicate their course together with the approximate depth at which they were installed. The marking or locating shall be coordinated to stay approximately two (2) days ahead of the planned construction.

While street lighting is under Contractor maintenance, the Contractor shall mark any existing or newly installed underground conduits with paint and flags, within 24 hours of the direction of the Engineer.

TRENCH CROSSING SEWERS AND UTILITIES

Where construction of the lighting installation requires crossing a sewer or underground utility, the Contractor shall locate the pipes or both as a line and grade before constructing the lighting. If it is determined that the proposed conduit (s) will intersect a sewer or underground utility if constructed as shown in these plans and details, the trench depth shall be increased to provide a minimum clearance of 18 inches for water lines (24 inches preferred) and 12 inches for all other pipes or utilities. Payment shall be incidental to any "CONDUIT" pay items used in these plans.

Conduit runs may deviate laterally as needed to avoid conflicts with catch basins, manholes, hydrants, and other roadway appurtenances.

COLUMBUS MATERIAL AND INSTALLATION SPECIFICATION (MIS)

Splices and connections in pole bases shall be incidental to "MIS-305", 6' BRACKET, T-BASE, 31' MOUNTING HEIGHT, SEE SCOPE OF SERVICES FOR COLOR AND LUMINAIRE TYPE, AS PER PLAN.

Splicing of cable in pull boxes as indicated in MIS-403 Section III.e shall be incidental to the "STREET LIGHTING CIRCUIT" pay item.

Trenching (MIS-700 section II.c) shall be incidental to any "CONDUIT" pay items used in these plans.

Per City of Columbus CMSC 1001.19.7, anchor bolts shall be included in the "FOUNDATION" pay item used in these plans.

STREET LIGHTING REQUIREMENTS

The General Contractor shall contact Scott Wolfe at 614-724-4351 (sawolfe@columbus.gov) or Steve Brutsche at 614-580-7113 (sbrutsche@franklincountyengineer.org) prior to beginning any wiring operations for a review of wiring procedures in the field with the electrical subcontractor. The electrical subcontractor's qualified representative shall be present with the Columbus Division of Electricity and Franklin County for a final inspection of the electrical installation. Also, the electrical subcontractor shall fill out the inspection sheets required by the Columbus Division of Electricity for inventory and tests of the installed items.

POWER SUPPLY FOR LIGHTING

Electric Power shall be obtained from American Electric Power (AEP) OR South Central Power.

- American Electric Power (AEP) South Central Power Co
- 850 Tech Center Drive 720 Mill Park Dr.
- Gahanna, OH 43230-6605 Lancaster OH 43130
- Phone: 614-883-6817 Phone: 1-800-282-5064

Power supplied shall be single phase, 120 Volts, three-wire grounded neutral and shall be metered. Separate cutoff switches shall be provided for each circuit at each control site as applicable to the plans.

MIS-603 MODIFIED, CONTROLLER, 3 WIRE, 120 V, PAD MOUNT, AS PER PLAN

In addition to the requirements of the City of Columbus Construction and Material Specifications (CMSC), Pedestal Mount Controller shall meet the requirements of MIS-603 with the following exceptions:

Controller shall be rated at 60 AMPS, 120 V.

Payment shall be made at the unit bid price for "MIS-603 MODIFIED, CONTROLLER, 3 WIRE, 120 V, PAD MOUNT, AS PER PLAN" which shall be in full compensation for all labor, materials, and incidentals required to complete this item in a satisfactory and workmanlike manner.

MIS-305, POLE, ALUMINIUM, 6' BRACKET, T-BASE, 31' MOUNTING HEIGHT, SEE SCOPE OF SERVICES FOR COLOR AND LUMINAIRE TYPE, AS PER PLAN

In addition to the requirements of the City of Columbus Construction and Material Specifications (CMSC), the aluminum pole and bracket arm shall meet the requirements of MIS-305 with the following exception:

Payment shall be made at the unit bid price for "MIS-305, POLE, ALUMINIUM, 6' BRACKET, T-BASE, 31' MOUNTING HEIGHT, SEE SCOPE OF SERVICES FOR COLOR AND LUMINAIRE TYPE, AS PER PLAN" which shall be in full compensation for all labor, materials, and incidentals required to complete this item in a satisfactory and workmanlike manner.

STREET LIGHT LUMINAIRE LED TEAR DROP STYLE

In addition to the requirements of the DOPW MIS-801 and the City of Columbus Construction and Materials Specifications, the LED luminaires for the street lighting units shall be as follows:

Holophane Espalade, Teardrop LED II Series, P60S, Type 3, 3000k color, 242 watts

Sternberg Libertyville, 4L LED with MDL10 Driver, Type 3, 3000k color, 224 watts

Or other if approved by the Engineer.

The luminaire housing shall be painted to match the light pole and bracket arm. See scope of services for paint color.

DRAWN BY: ACK
CHECKED: JDH
DATE: 01/01/2025

STREET LIGHTING NOTES

FRANKLIN COUNTY ENGINEER

DRAWING: P:\Proj_Review\FCEO_Standards\Design_Standards\General_Notes.dwg
January 24, 2025, 11:09pm

ITEM 630 GROUND MOUNTED SUPPORT, AS PER PLAN

All ground mounted post supports shall be a square post with anchor base as per detail on ODOT Standard Drawing TC-41.20. All posts shall be 2"x2" 12 gauge square tubing with open holes and all anchor bases shall be 2 1/4" x 2 1/4" 12 gauge square tubing with open holes.

ITEM 630 SIGN, FLAT SHEET, AS PER PLAN

In addition to 630, all reflective sign sheet material shall be 3M Diamond Grade DG3, Avery Dennison OmniCube or approved equal. The material shall meet ASTM Type XI specifications. No signs shall be digitally printed. All shall use either reverse silk screen transparent ink, or transparent acrylic electronic cuttable film or direct applied reflective copy. Whatever methodology is used, all must be part of a matched component system.

ITEM 630 REMOVAL OF GROUND MOUNTED SIGN AND STORAGE

Ground mounted signs shall be removed as shown in the plans and stored for pickup by the County. The Contractor shall notify the County's Mobility Department (614-525-6037) within one week of the sign's removal.

ITEM 630 REMOVAL OF POLE MOUNTED SIGN AND DELIVERY, AS PER PLAN

Street name signs shall be removed as shown in the plans. The Contractor shall deliver the signs and brackets to the Engineer's Office at 970 Dublin Rd, Columbus, OH, 43215. The Contractor shall notify the County's Mobility Department (614-525-5318) 2 days in advance of delivering the signs.

ITEM 630 REMOVAL OF STREET NAME SIGN SUPPORT AND FOUNDATION, AS PER PLAN

The Contractor shall remove the street name sign supports and anchor foundations as shown in the plans. The Contractor shall deliver the supports and foundations to the Franklin County Engineer's Office at 970 Dublin Rd, Columbus, OH, 43215. The Contractor shall notify the County's Mobility Department (614-525-5318) 2 days in advance of delivering the signs.

ITEM 630 STREET NAME SIGN, INSTALL ONLY, AS PER PLAN

All street name signs shall be furnished by the Franklin County Engineer's Office. The Contractor shall pick up the signs from the Engineer's Office at 970 Dublin Rd, Columbus, OH, 43215. The Contractor shall notify the County's Mobility Department (614-525-5318) 30 days in advance of installation. This item does not include any hardware necessary for sign installation.

ITEM 630 SIGNING, MISC.: CORPORATION SIGNS, INSTALL ONLY, AS PER PLAN

All corporation signs shall be furnished by the Franklin County Engineer's Office. The Contractor shall pick up the signs from the Engineer's Office at 970 Dublin Rd, Columbus, OH, 43215. The Contractor shall notify the County's Mobility Department (614-525-5318) 30 days in advance of installation. The contractor shall provide any hardware necessary for sign installation.

ITEM 630 STREET NAME SIGN SUPPORT, AS PER PLAN

The sign support shall be a 16' long, 6" to 4" tapered aluminum pole, 0.188" wall thickness, satin finish with cap, and 9" to 10" dia. bolt circle base flange with bolt covers, as manufactured by Hapco Poles, Cat. #TT64DA162018190 (Dwg. #A76960), P&K Tubular Products, or approved equal. Approximately 15 shims shall be provided with each pole.

The foundation shall be galvanized tubular steel, 60" long, 6.63" dia., and .28" wall thickness, with baseplate, 2.5"x12" access slots, helix auger with pilot point, as manufactured by CHANCE (Hubbell Power Systems) Cat. # C11232JG4VL, Pelco Products Inc., or approved equal. Installation shall be achieved by the use of a digger/derrick truck that meets the foundation manufacturers specification. Care must be taken at the beginning of installation to keep the foundation plumb. If objects are encountered that make this impossible, the foundation shall be removed and relocated.

Payment for furnishing and installing the sign supports, foundations, and all miscellaneous hardware needed to completely install the assembly shall be included in the unit price bid per each for Item 630 Street Name Sign Support, As Per Plan.

ITEM 630 SIGNING MISC.: STREET NAME SIGN BRACKET, AS PER PLAN

Each street name sign will require two cantilever brackets (one for top and one for the bottom of each sign) varying from sizes 36" up to 72" in length.

Each 36", 42", or 48" cantilever bracket shall be a Signfix HDTE (Heavy-Duty Double Tee), or equal, and shall include one offset banding plate attached to the cantilever bracket, and one banding strap.

Each 54", 60", 66" or 72" cantilever bracket shall be a Signfix RHDTE (Ribbed Heavy-Duty Double Tee), or equal, and shall include two offset banding plates, mounted back-to-back, and attached to the cantilever bracket, and two banding straps.

All banding material used to install the street name signs shall be stainless steel (bands and banding plates). The bands shall be 3/4" width with a thickness of 0.030", as manufactured by BAND-IT (Ultra-Lok 200 series), Independent Metal Strap (3430-SS), or approved equal.

Payment for Item 630 Signing Misc.: Street Name Sign Bracket, As Per Plan includes all labor, material, and hardware needed to attach the street name signs to the sign supports. A quantity of two Street Name Sign Brackets are required to attach each Street Name Sign.

ITEM 630 SIGNING, MISC.: SCHOOL FLASHER ASSEMBLY

The school flasher supports shall be a 18'-4" long, 7" to 4 1/2" tapered aluminum pole, 0.188" wall thickness, satin finish, 3/8" x 5" square aluminum plate with 1/2" diameter hole, a 15" bolt circle base flange with bolt covers, and transformer base with door, as manufactured by Hapco Poles (Dwg. No. SKKPOPP26142C), P&K Tubular Products, or approved equal.

ITEM 630 SIGNING, MISC.: SCHOOL FLASHER ASSEMBLY (CONT'D)

The foundation shall be galvanized tubular steel, 72" long, 8.63" dia., and .25" wall thickness, with baseplate, 2.5"x18" access slots, helix auger with pilot point, as manufactured by CHANCE (Hubbell Power Systems) Cat. # T112-0426, Pelco Products Inc., or approved equal. Installation shall be achieved by the use of a digger/derrick truck that meets the foundation manufacturers specification.

The flasher controller cabinet shall be model #FC104 manufactured by Eagle. The flasher panel shall be a NEMA 2 circuit flasher. The lock shall be a #2 Corbin Lock with 2 keys. The time switch clock shall be supplied by FCEO.

The signal heads shall be 12" polycarbonate with cutaway visors including 12" yellow LED signals, Gelcore model DR6-YTFB-17A, Dialight, or approved equal. Flasher mounting hardware shall include Pelco mounting brackets Part #SE-3036 complete with two hub plates, Pelco part #SE3057. Each signal head shall be supported by two (an upper and a lower) Pelco arms. Each assembly shall include 3 beacons (two beacons front facing and one beacon rear facing)

Wiring to the signal heads shall be #14 AWG, 2 conductor signal cable. The power service supplying the pole shall be #10 600V pole and bracket cable, and include Homac (or equal) type Y flood seal street lighting fuse/disconnect kits located in the breakaway base.

The S5-H1 sign shall be 75"x36". Type J sheeting shall be used. All school signs shall be fluorescent yellow green in color as allowed per section 7B.07 of the OMUTCD. This sign shall be supported to the HAPCO pole via 3- PELCO AS-0128-30-29-PNC "astro bracs".

Payment will be at the unit contract price per each School Flasher Assembly, As Per Plan and shall include all labor, materials, tools, equipment and other incidentals necessary for each School Flasher Assembly furnished, in place, complete and accepted.

ITEM 630 STREET NAME SIGN SUPPORT, ROUNDABOUT, AS PER PLAN

The sign support shall be an 8'-6" long, 6" to 4" tapered aluminum pole, 0.188" wall thickness, satin finish with cap, and 9" to 10" dia. bolt circle base flange with bolt covers, as manufactured by Hapco Poles, Cat. # TT64DA072018100 (Dwg. # A30128), P&K Tubular Products, or approved equal. Approximately 15 shims shall be provided with each pole. The sign shall have a minimum vertical clearance of 7' above the edge of the travelled way.

The foundation shall be galvanized tubular steel, 60" long, 6.63" dia., and .28" wall thickness, with baseplate, 2.5"x12" access slots, helix auger with pilot point, as manufactured by CHANCE (Hubbell Power Systems) Cat. # C11232JG4VL, Pelco Products Inc., or approved equal. Installation shall be achieved by the use of a digger/derrick truck that meets the foundation manufacturers specification. Care must be taken at the beginning of installation to keep the foundation plumb. If objects are encountered that make this impossible, the foundation shall be removed and relocated.

PAVEMENT MARKING NOTES

ITEM 621 RAISED PAVEMENT MARKER, AS PER PLAN

The use and placement of raised pavement markers shall comply with ODOT SCD TC-65.10 and TC-65.11. Center line markers shall be placed between the lines where double solid, or solid/dashed lines are used. Markers installed along an edge line or channelizing line shall be placed so that the casting is no more than 1 inch from the near edge of the line. Markers installed along a lane line or dashed yellow center line shall be placed between and in line with the dashes.

ITEM 644 - THERMOPLASTIC PAVEMENT MARKING (BY TYPE), AS PER PLAN

This work shall conform to ODOT Item 644 Thermoplastic Pavement Markings with the following exceptions:

1. The Contractor shall provide a TE-24 certification for thermoplastic used on County projects.
2. The Contractor shall contact the Engineer and Mobility Engineer representative 5 days prior to pre-mark to schedule an onsite coordination meeting.
3. The Contractor shall lay out the locations of all lines, words, and symbols to ensure their proper placement. No striping shall be performed until pre-mark has been approved by Engineer.
4. Damage resulting from the daily operations of the work outlined in this contract to pavement markings on roadways outside of the designated work area shall be corrected at the Contractors expense.

ITEM 644 - PAVEMENT MARKING, MISC. DOTTED LINE, WHITE

The dotted line shall be 24" wide and have a 2' segment. There shall be a 2' gap between each segment.

ITEM 645 - EDGE LINE, 6", AS PER PLAN

Prior to the placement of the Item 645 Edge Line, the Contractor shall cut a 150 mil (3.81 mm) deep groove in the approach slabs and bridge deck area that is the width of the new pavement marking plus 2 inchs on each side. Black Contrast Markings per ODOT TEM shall be used for edge lines on concrete pavement. All materials, equipment and labor required for the pavement grooving and application of the performed tape pavement markings shall be included in the unit price for Item 645, Edge Line, 6", As Per Plan.

ITEM 645 - CENTER LINE, 6", AS PER PLAN

Prior to the placement of the Item 645 Center Line, the Contractor shall cut a 150 mil (3.81 mm) deep groove in the approach slabs and bridge deck area that is the width of the new pavement marking plus 1 inch on each side. All materials, equipment and labor required for the pavement grooving and application of the performed tape pavement markings shall be included in the unit price for Item 645, Center Line, 6" As Per Plan.

ITEM 645 - CHANNELIZING LINE 8", AS PER PLAN

Prior to the placement of the Item 646 Center Line, the Contractor shall cut a 150 mil (3.81 mm) deep groove in the approach slabs and bridge deck area that is the width of the new pavement marking plus 2 inchs on each side. Black Contrast Markings per ODOT TEM shall be used for channelizing lines on concrete pavement. All materials, equipment and labor required for the pavement grooving and application of the performed tape pavement markings shall be included in the unit price for Item 645, Channelizing Line 8", As Per Plan.

ITEM 630 SIGNING, MISC.: ADVANCE ROUNDABOUT WARNING SIGN ASSEMBLY

The sign support shall be a variable height, 7" to 4 1/2" tapered aluminum pole, 0.188" wall thickness, satin finish with cap, 15" bolt circle base flange with bolt covers, and transformer base with door and stainless steel screws, as manufactured by Hapco Poles (Dwg. No. A18808), P&K Tubular Products, or approved equal.

The foundation shall be galvanized tubular steel, 72" long, 8.63" dia., and .25" wall thickness, with baseplate, 2.5"x18" access slots, helix auger with pilot point, as manufactured by CHANCE (Hubbell Power Systems) Cat. # T112-0426, Pelco Products Inc., or approved equal. Installation shall be achieved by the use of a digger/derrick truck that meets the foundation manufacturers specification.

Advance roundabout warning signing shall be attached via the following:

- 48" x 48" warning sign secured to pole via 4 attachment assemblies.
- 30" x 30" speed plaque secured to pole via 2 attachment assemblies.
- 48" x XX" street name plaque secured to pole via 2 attachment assemblies.

Each attachment assembly shall consist of the following hardware:

- 1 1/2" SS brackets
- 3/4" X .044" SS banding
- 5" x 4" x 0.100 aluminum bearing plate with each bracket (between the bracket and the sign)
- 5/16" SS bolts attaching the sign to the bracket

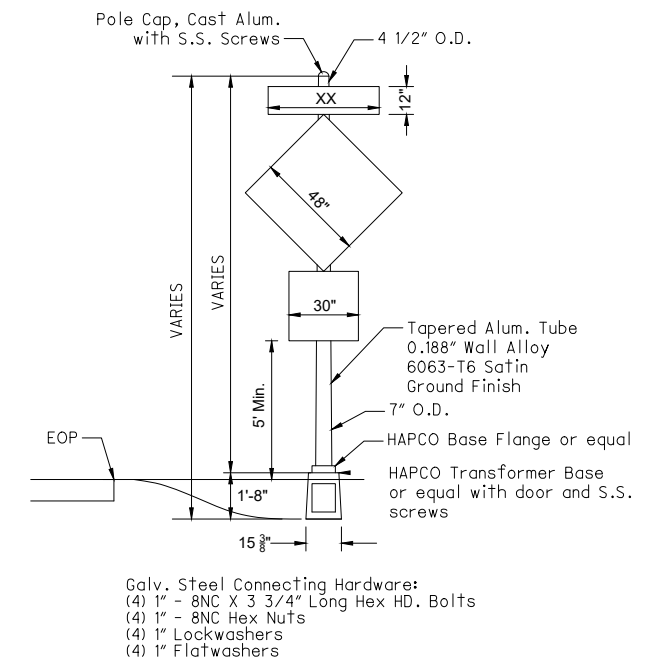

Signing notes and details to be included in all roundabout plans

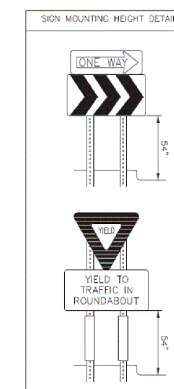

NOTE: CONTRACTOR SHALL FIELD VERIFY LOCATION OF PROPOSED SIGNS LOCATED IN ROUNDABOUT. THE CONTRACTOR SHALL ADJUST LOCATIONS IF SIGNS DETERMINED TO BE BLOCKED AS DETERMINED BY THE ENGINEER.

PLAN AND SPECIFICATION COMPLIANCE

The Contractor shall furnish and install traffic signal devices in compliance with these plans and specifications, the 2023 ODOT Construction and Material Specifications and its supplemental specifications, Ohio Manual of Uniform Traffic Control Devices for Streets and Highways, and the "TC" standard construction drawings issued by ODOT (supplements the plan specifications). These specifications set forth the design and minimum operating requirements for traffic signal equipment. The Franklin County Engineer shall determine whether the supplied items meet or exceed these requirements.

Traffic signal control equipment shall meet or exceed the standards specified in the following documents:

- (a) Specifications listed in this plan
(b) NEMA standards publication no. TS2-2016 (or current NEMA issue) and/or
(c) 2023 ODOT Construction and Material Specifications 625, 630, 632, 633, 725, 730, 732, 733

In case of a conflicting specification statement, the specification document hierarchy shall be in the order listed from (a), highest, to (c), lowest.

ELECTRICAL SERVICE, COORDINATION, AND METERING

The Contractor is responsible for all costs associated with establishing electrical service and coordinating with American Electric Power. Additionally, all new and replacement traffic signals energized by AEP will need to be metered. The Contractor shall call AEP at 1-800-672-2231, and provide the exact address of the traffic signal controller. The order will be sent to AEP's Engineering Department, who will contact the Contractor, and set up an appointment, as needed.

(South Central Power SCPC also provides electric service for Franklin County projects. Their number is 1-800-282-5064)

SIGNAL INSTALLATION INSPECTION

The Contractor shall notify the Franklin County Mobility Department at (614) 525-6158 (5) work days before starting any traffic signal work including signal pole foundations, pull box, traffic signal conduit, signal or loop wiring, lashing or loop cutting. If the Contractor stops any traffic signal installation work for greater than three consecutive working days for any reasons, re-notification is required.

Special attention should be paid to notification for traffic signal loop installation. Any loop cutting, loop lead-in pulling, or wire splicing done without notification to the Franklin County Mobility Engineer as specified above may be required to be redone at the Contractor's expense as directed by the Engineer.

TEN-DAY TEST REQUIREMENTS

Franklin County requires a 10 day test to start after installation is 100% complete. No partial tests will be conducted. The Contractor shall submit a written request to the Franklin County Mobility Engineer stating that the signal installation is 100% completed and a start date for the ten day test is requested. If less than 100% completion is detected upon inspection by the County or any major malfunction (controller, interconnect equipment, loop amplifiers, etc.) is detected, then the ten-day shall be completely restarted.

TESTING

The Contractor shall submit certified documentation, in accordance with 632.28, for the following tests (a form is available from the County's Mobility Department):

- 1. Ground test
2. Short-circuit test
3. Circuit continuity test
4. Cable insulation test
5. Functional test

As an alternative, the Contractor may request that a person from the County's Mobility Department be present. To make arrangements, call 614-525-6158. Any test conducted and not certified (or if the test is conducted without the county's traffic representative) shall be re-done.

MATERIAL INFORMATION SUBMITTAL AND TESTING CERTIFICATION

The Contractor shall submit, for County approval; diagrams, brochures or other descriptive material for the items the Contractor intends to furnish that have not been specifically named by product number. When requested, the manufacturer shall provide a certified letter stating that the controller, malfunction management unit (MMU), load switch units and ac line filters have been successfully tested in exact accordance with the NEMA environmental standards and test procedures. Such testing shall have occurred no more than six-months prior to the date of this contract. This six-month requirement may be waived by the Franklin County Mobility Engineer if the manufacturer can satisfactorily demonstrate to the Mobility Engineer that the supplied equipment is identical to the equipment that was previously tested and that the manufacturer request this testing requirement be waived. Any redesign or changes of any type including any component changes which would make the bid control equipment not identical to tested control equipment will require the above equipment to be re-certified.

SHOP DRAWINGS

Prior to incorporation, the Contractor shall submit to the Engineer shop drawings and catalog cuts which identify and describe each manufactured item which is being incorporated into the construction. Certify in writing that each manufactured item is in conformance with all contract requirements for that item. Each submittal shall include a Title Sheet describing: 1) Project Name; 2) Equipment Submitted; 3) Material Item Number; and, 4) Quantity. Each item drawing shall indicate the projects number (including the construction year) and the bid reference number (with item description) under which the item is being installed. The documentation shall contain all of the information needed to allow the Engineer to determine that the item to be supplied meets all applicable requirements along with all of the information needed by the maintaining agency to obtain an identical replacement unit from the manufacturer.

When a given item is to be incorporated into the construction under multiple bid item reference numbers, furnish a separate and complete documentation package for each bid item reference number under which the item is to be installed. When multiple items are to be incorporated under a single bid reference number, submit the documentation for all such items together.

GROUNDING AND BONDING

The requirements of the Construction and Material Specifications (C&MS) and the HL and TC series of Standard Construction Drawings are modified as follows:

- 1. All metallic parts containing electrical conductors shall be permanently joined to form an Effective Ground Fault Current Path back to the grounded conductor in the power service disconnect switch.
a. Provide an equipment grounding conductor in metallic conduits (725.04) in addition to the conductors specified and bond the conduit to this grounding conductor.
b. Metallic conduit carrying the loop wires from in the pavement to the pull box splice location will only be bonded at the pull box end, and will not contain an equipment grounding conductor.
c. Metal pull box lids shall be bonded by attachment of the equipment grounding conductor to the frame diagonal as provided on HL-30.11.
d. If multiple conduit runs begin and end at the same points, only one equipment grounding conductor is required.
e. If an equipment grounding conductor is needed in conduit between signalized intersections for underground interconnect cable, the grounding system for each signalized intersection will be separated about midway between the intersections.
f. The messenger wire at signalized intersections will be used as the conductive path from corner to corner if conduit is not provided under the roadway. When conduit connects the corners of an intersection, an equipment grounding conductor shall be used in the conduit.
2. Conduits.
a. The 725.04 conduit shall have grounding bushings installed at all termination points. The bushing material shall be compatible with galvanized steel conduit and the grounding lug material shall be compatible for use with copper wire. Threaded or compression type bushings may be used.
b. Both ends of metallic conduit shall be bonded to the equipment grounding conductor.
c. Metallic conduit may be bonded to metallic boxes through the use of conduit fittings UL approved for this type of connection, with the box bonded to the equipment grounding conductor.
3. Wire for grounding and bonding. Use insulated, copper wire for the equipment grounding conductor. Bonding jumpers in boxes and enclosures may be bare or insulated copper wire. Wire size shall be as follows:
a. Use 4 AWG between the power service and supports, poles, pedestals, controller or flasher cabinets.
b. The insulation shall be green or green with yellow stripe(s). For 4 AWG or larger, insulation may also be black with green tape/labels installed at all access points.
4. Ground Rod
a. A 3/4 inch Schedule 40 PVC conduit will be used in foundations and concrete walls for the grounding conductor (ground wire) raceway to the ground rod. Should metallic conduit be used, both ends of the conduit shall be bonded to the grounding conductor.
b. The typical grounding conductor (ground wire) shall be 4 AWG insulated, copper.
5. Power Service and Disconnect Switch
a. At the power service location, the grounding conductor (ground wire) from the disconnect switch neutral (AC-) bar to the ground rod shall be a continuous, unspliced conductor. If spliced, it shall be an exothermic weld butt splice.
b. The service neutral (AC-) shall only be connected to ground at the primary power service disconnect switch.
i. NEMA controller cabinets: If a power service disconnect switch is located before the controller cabinet, the neutral (AC-) and the grounding bars in the controller cabinet shall not be connected together as shown in NEMA TS-2, Figure 5-4.
ii. If secondary disconnect switches are connected after the primary disconnect switch, the neutral (AC-) shall only be grounded at the primary switch. Equipment grounding conductors shall be brought to the primary switch, but shall be grounded at both secondary and primary switches.

Payment for the above work shall be incidental to the various bid items.

TRANSITION TO SIGNAL CONTROL

The signal shall flash for seven (7) days prior to being placed on regular cycling operation. The signal shall not be placed on flash until the installation has been checked and the Contractor has approval to flash the signal. The signal will not be placed on flash until the permanent pavement markings and lane control signs have been installed with the exception of the intersection stop lines. Temporary pavement markings may be used in lieu of permanent pavement markings if they are installed as shown on the permanent pavement marking layout. The stop lines shall be in place prior to the signal being placed on regular operation.

The Contractor shall flash the new signal installation for 7 consecutive days before beginning cycling operation. The 10 day performance test shall not be started until after the 7-day flashing period.

Standard Construction Drawing MT-120.00 by the Ohio Department of Transportation shall be invoked for transition to signal control. The following signs shall be erected on the mainline approaches:

- W24-H2a-60 - "New Signal Will Begin Stop and Go "Date"
W3-3-48 - "Signal Ahead"
W16-15P-24 - "New"
W3-4-48 - "Be Prepared to Stop"
W16-15P-24 - "New"

Existing stop controlled approaches (minor street) shall be exempt from all signage as illustrated on the MT-120.00 Standard Construction Drawing, except for the W24-H2a-60 signs.

Flags and Type B flashing lights shall be required. After the signal is placed on stop and go operation, the Contractor shall remove the W24-H2a-60 signs. After the required 21-30 day period the Contractor shall remove the W16-15P-24 "New", the W3-3-48 "Signal Ahead", the W16-15P-24 "New", and the W3-4-48 "Be Prepared to Stop" signs.

Payment for all labor, equipment and materials necessary to complete this item of work shall be included in the lump sum price bid for Item 614 Maintaining Traffic, As Per Plan.

ITEM 625 PULL BOX, 725.06, (13"x24") (17"x30") (24"x36") AS PER PLAN

Pull boxes shall be polymer concrete and shall be manufactured by Strongwell (Quazite), Oldcastle "H Series", or approved equal. All pull boxes shall be PG style with HA cover. Covers shall be stamped "TRAFFIC" and shall have skid resistance surface. The cover shall be secured to the box with two stainless steel hex-head bolts, washers, and inserts. All pull boxes shall be set to final grade or flush with pavement.

ITEM 625 PULL BOX, CONCRETE, 27", AS PER PLAN

The Contractor shall furnish and install concrete pull boxes in accordance with City of Columbus CMS 625.11 and STD DWG #4021. All pull boxes shall have "TRAFFIC" embossed on the lid. Separate or bonded tags will not be permitted.

In addition to the STD DWG #4021, one coat of Hydrozo Enviroseal 40, Rainstopper 140, or Chemtrete BSM40 shall be applied to the inside and outside of the pull box. The lid shall have a lip for lifting. All conduits connecting a pull box directly to any equipment cabinet shall be sealed using layers of alternating steel wool and duct seal at both ends, within the pull box and the cabinet. Any slack or excess cable to be coiled in the pull box shall be placed around the inside box perimeter. All coiled cables shall be tie wrapped and clearly identified within the pull box.

ITEM 625 PULL BOX, CONCRETE, 32", AS PER PLAN

The Contractor shall furnish and install concrete pull boxes in accordance with City of Columbus CMS 625.11 and STD DWG #4022. All pull boxes shall have "TRAFFIC" embossed on the lid. Separate or bonded tags will not be permitted.

In addition to the STD DWG #4022, one coat of Hydrozo Enviroseal 40, Rainstopper 140, or Chemtrete BSM40 shall be applied to the inside and outside of the pull box. The lid shall have a lip for lifting. All conduits connecting a pull box directly to any equipment cabinet shall be sealed using layers of alternating steel wool and duct seal at both ends, within the pull box and the cabinet. Any slack or excess cable to be coiled in the pull box shall be placed around the inside box perimeter. All coiled cables shall be tie wrapped and clearly identified within the pull box.

TRAFFIC SIGNAL NOTES
DRAWN BY: ACK
CHECKED: JDH
DATE: 01/01/2025
FRANKLIN COUNTY ENGINEER
16
20

ITEM 625 CONDUIT, 3", CONCRETE ENCASED, AS PER PLAN

The Contractor shall furnish and install a complete interconnect conduit bank system. The conduit bank shall be installed as detailed with respect to the conduit arrangement, horizontal alignment and profile requirements. This item shall maintain proper clearance requirements from both existing and proposed facilities. Protection and temporary support of existing utilities shall also be included.

The Contractor shall furnish and install EPC-80-PVC conduits and fittings for fiber optic interconnect cabling that are in conformance with NEMA Standard TC-2. The conduit shall have a minimum wall thickness of 0.300". Refer to City of Columbus STD DWG #4000 and 4001 for conduit placement and trench width details and other requirements.

Conduit banks shall include a 1 1/2 inch conduit with tracer wire installed. The cost for 1 1/2 inch conduit and the tracer wire shall be incidental to the cost of this pay item.

After conduit runs are built, the Contractor shall pull a mandrel 1/4 inch smaller in diameter than the conduit, and a suitable swab or cleaning device designed to clear the conduit of small pebbles, etc. The Contractor shall notify the Engineer prior to performing this phase of the work so that the work may be observed.

Additionally, the Contractor shall install non-organic fiberglass pull tape with a minimum 1800 ft./lbs. tension strength in all conduit. The pull tape and its installation shall be incidental to the cost of this pay item.

A bell end shall be placed on the ends of all conduit terminations and sealed with a suitable removable plug immediately upon installation.

This item of work shall include furnishing and installing conduit, conduit spacers, encasement, pull tape and tracer wires as specified for the proposed interconnect conduit bank details in the Plans.

ITEM 625 CONDUIT, 3", 725.051, As Per Plan

The Contractor shall furnish and install EPC-80-PVC conduits and fittings for fiber optic interconnect cabling that are in conformance with NEMA Standard TC-2. The conduit shall have a minimum wall thickness of 0.300".

The trench for the conduit shall be 36" deep and backfilled to a depth below ground of 12". A No. 10 AWG tracer wire and caution tape shall then be installed, after which the remaining 12" of backfill material shall be placed to the finished grade.

After conduit runs are built, the Contractor shall pull a mandrel 1/4 inch smaller in diameter than the conduit, and a suitable swab or cleaning device designed to clear the conduit of small pebbles, etc. The Contractor shall notify the Engineer prior to performing this phase of the work so that the work may be observed.

Additionally, the Contractor shall install non-organic fiberglass pull tape with a minimum 1800 ft./lbs. tension strength in all conduit. The pull tape and its installation shall be incidental to the cost of this pay item. A bell end shall be placed on the ends of all conduit terminations and sealed with a suitable removable plug immediately upon installation.

This item of work shall include furnishing and installing conduit, pull tape and tracer wire as specified for the proposed interconnect conduit shown in the Plans.

ITEM 625 DISTRIBUTION CABLE, MISC.: NO. 12 AWG, 600 VOLT

A green colored insulated cable shall be used for the ground wire (GND) where indicated. This GND cable shall be separate from the ground wire, but shall be connected to the same grounding bolt used for the ground wire attachment at the pole. The GND cable shall be tagged as: "GND SYS" at all pole locations & control cabinet. Payment shall be as per Item 625.

ITEM 632 VEHICULAR SIGNAL HEAD, (BY SIZE AND TYPE), AS PER PLAN

In addition to 632 and 732, all vehicular signal heads shall be aluminum and shall contain 12" LED traffic signal lamp units manufactured by Gelcore (GT1), Dialight (430 series), or approved equal.

ITEM 632 PEDESTRIAN SIGNAL HEAD LED POLYCARBONATE COUNTDOWN, TYPE D2, AS PER PLAN

In addition to 632 and 732, the pedestrian signal head shall be polycarbonate 16"x18" module type as manufactured by Gelcore (model #PS7-CFF1-VLA), Dialight (model #430-6479-001X), or approved equal. Pedestrian heads shall be banded to the strain pole/pedestal. The signal indications shall be fully filled-in hand/man symbols.

ITEM 632 PEDESTRIAN PUSHBUTTON, AS PER PLAN

Pedestrian pushbuttons shall be Navigator APS two-wire configuration and shall be manufactured by Polara Inc., Novax VB3, or approved equal. Options to be included shall be "voice on location" and face plate a. The lead-in cable for pedestrian push buttons shall be loop detector lead-in cable. Mount the center of the pushbutton 42" above pedestrian pathway surface.

ITEM 632 PEDESTAL FOUNDATION, AS PER PLAN

The pole base foundation sides shall be oriented parallel to the sidewalk, back of curb, or edge of pavement, as shown on the signal plans. The top of the foundation shall be flush with any adjacent sidewalk or concrete area, except where the ground rises steeply behind the sidewalk or concrete area. In that case, the back of the foundation shall match the ground slope, and the street side of the foundation shall be above the sidewalk or concrete area, and be completely outside of the sidewalk or concrete area. One spare 2" conduit ell shall be installed in each pole foundation. See the pole orientation chart for the angular position. All anchor bolts shall be ASTM F-1554 Grade 105 with rolled thread. Bolt covers shall be installed. The anchor bolts and conduit ells are incidental to this item. Payment shall be made on a per each basis for Item 632 Pedestal Foundation, As Per Plan.

ITEM 632 PEDESTAL, (BY SIZE), TRANSFORMER BASE, AS PER PLAN

Pedestals shall be provided and installed as shown in the details in this plan. All signal cables shall be installed inside the poles. Conduit risers shall not be used.

Payment shall be made on a per each basis for Item 632 Pedestal, Transformer Base, As Per Plan.

ITEM 632 COVERING OF VEHICULAR (OR PEDESTRIAN) SIGNAL HEAD, AS PER PLAN

In addition to 632, heavy duty plastic bags shall be permitted. Two bags per head shall be used. The bags shall be securely lashed down so the wind does not rip them from the signal head. All signal heads while covered shall be dark either by removing, unscrewing, or disconnecting the power to the LEDs. No covered head shall block the view of an operating head. Any existing vehicular signal head that is not functional shall be removed immediately or covered.

ITEM 632 REMOVAL OF TRAFFIC SIGNAL INSTALLATION, AS PER PLAN

In addition to 632.26, the Contractor shall deliver the following items to the Franklin County Engineer's Office Mobility Department at 970 Dublin Road: vehicular signal heads along with all mounting hardware, push buttons and signs, street name signs (unless otherwise directed), pull boxes, controller and UPS cabinets, cabinet equipment, strain poles, pedestals, and any other salvageable item as directed by the Engineer. All items not designated for salvage shall be disposed of by the Contractor.

ITEM 632 STRAIN POLE FOUNDATION, AS PER PLAN

The pole base foundation sides shall be orientated parallel to the sidewalk or back-of-curb or edge-of-pavement as shown on the signal plans. The top of the foundation shall be flush with any adjacent sidewalk or concrete area except where the ground rises steeply behind the sidewalk or concrete area. Then the back side of the foundation shall match the ground slope and the street side of the foundation shall be above the sidewalk or concrete area and completely out of the sidewalk or concrete area. One spare 2" conduit ell shall be installed in each pole foundation. See pole orientation chart for angular position. All anchor bolts shall be ASTM F-1554 grade 105 with rolled thread. Bolt covers shall be installed. The anchor bolts and conduit ells are incidental to this item.

ITEM 632 POWER SERVICE, AS PER PLAN

The power service drop shall be from the approximate location shown in the plans. Any power company "make ready" charges will be reimbursed "at cost" with no mark up. The Contractor shall contact AEP (614-883-7935) to make arrangements for the power service. AEP shall make all of the transfers of power service and under no circumstances shall the Contractor attempt to do this item of work. The power service shall be 240V. A disconnect switch shall be installed (not on the controller cabinet).

Provide an available fault current sign on the outside front door of the service disconnect enclosure in accordance with the 2011 National Electrical Code Paragraph 110.24.

Payment shall be as per item 632.

ITEM 632 DETECTOR LOOP, AS PER PLAN

The work to install the detector loops shall conform to the Ohio Department of Transportation standard construction drawing (ODOT SCD) TC-82.10 (dated 7/17/15 or later) and to the following provisions:

1. Loop sealant shall be Thorac Gold Label Flex, 3M brand or approved equal. The Contractor shall take care in the placement of the loop sealant so that all sealant is placed in the saw slot.
2. One-inch (1") steel conduit shall be installed from the sawcut away from the pavement to the pull box or conduit riser. Installation shall follow detail of an ODOT standard drawing TC-82.10.
3. Loop lead-in and homerun cables shall be soldered and enclosed within an epoxy encapsulated splice enclosure. Cost for splices between loop wire and lead-in cables shall be included in the bid price for loop wire.
4. All loop lead-in cable shall be identified and tagged in the pull box and in the controller cabinet. The plastic tag shall identify the loop as NBLT, EB, SBRT, etc.
5. Each loop lead-in cable shall be wired directly to the cabinet. No splices are permitted.

ITEM 633 CONTROLLER UNIT, TYPE TS-2/A2, W/TYPE TS-2 CABINET, AS PER PLAN

The controller shall be NEMA TS-2 - Siemens m60 series, Econolite Cobalt series, or approved equal. If a Siemens controller is supplied, the controller shall come equipped with SEPAC NTCIP Version 4.54 (to be compatible with CTSS Centrac System). The remainder of the controller assembly equipment will comply with NEMA TS-2.

Two detector racks, sixteen channels each, shall be installed in each controller cabinet (two TS-2 configuration 2 detector racks.)

The conflict monitor will be an EDI MMU2-16LE or equal.

The controller cabinet shall have two (2) ground rods installed one (1) foot apart. The rods shall be connected by a ground wire jumper that is welded to each rod.

The loop detector unit shall be four channel Reno Model E-1200, Oracle (EDI) 4E, or approved equal. Each channel of the amplifier shall be labeled to identify the location of the loop(s).

The controller cabinet enclosures shall be a type TS-2 NEMA P44 controller cabinet. Controller cabinets with master controllers shall be NEMA P44. The terminal facilities shall be TS-2 configuration 3 (12 load switch sockets). This item shall also include a 12" controller cabinet riser.

Furnish an aluminum shelf with integral storage compartment in the space immediately below the controller. Ensure the storage compartment has telescoping drawer guides for full extension. Ensure the compartment top has a non-slip plastic laminate attached. The traffic signal cabinet shall also have four (4) additional electric receptacles.

ITEM, 633 CABINET FOUNDATION, AS PER PLAN

The cabinet foundation shall be sized to accommodate the UPS cabinet on the same foundation.

ITEM, 633 CONTROLLER WORK PAD, AS PER PLAN

The Controller Work Pad shall be sized to accommodate the UPS cabinet on the same work pad.

ITEM, 633 CONTROLLER ITEM, MISC.: UNINTERRUPTIBLE POWER SUPPLY (UPS), 1,000 WATT

This item of work shall consist of furnishing and installing a battery backup ups system to provide uninterruptible, reliable, emergency power to a traffic signal intersection in the event of a power failure or interruption. The transfer from utility power to battery power shall not interfere with the normal operations of the traffic control system. The system shall be self-contained including all UPS hardware, the required number of batteries and its own separate ventilated enclosure. This item shall also include an 8" UPS cabinet riser.

Payment shall be made at the unit price bid per each, complete and in place, all connections tested and accepted.

SIGNAL INSTALLATION & MAINTENANCE PERSONNEL REQUIREMENTS

The Contractor shall assign a supervisor for this project. The supervisor shall be a full time employee of the Contractor. The Contractor shall not change a supervisor assigned to a project without written notice. An IMSA Level 2 certified traffic control technician(s) shall be available on a 24-hour per day per week basis. Names, local addresses, telephone numbers and copies of all certifications must be submitted to the Engineer.

All controller work as defined below in items 1 through 4 shall be performed by an International Municipal Signal Association (IMSA) level two certified technician.

1. Back panel wiring terminations
2. Programming
3. Turn on
4. Troubleshooting

The Contractor shall also have a foreman assigned to each crew performing work for this project. A foreman shall be present at all times when work is performed by the crew. Each foreman shall be an IMSA level one certified technician. The Contractor shall provide prior verbal notice to the Project Engineer in order to replace a crew foreman. In addition, any trade person performing work as defined below in items 1 through 7 shall be an IMSA level one certified technician.

- | | |
|--------------------------------|------------------------------|
| 1. Cable splices | 5. Ground rod testing |
| 2. Signal head installation | 6. Cable insulation testing |
| 3. Cable and wire installation | 7. Field wiring terminations |
| 4. Power service installation | |

INSTALLATION LAYOUT

All traffic signal supports and all other stationed signal items shall be located and marked by a professional surveyor using the station numbers and offsets provided in these plans. The surveyor shall set proper pole and cabinet foundation elevations and stake each pole foundation angle so it matches the walk concrete angle. Project personnel shall approve all foundation locations and elevations prior to the Contractor installing them. Costs incurred for this service shall be incidental to the cost of the project or provided under a construction layout stake item.

UPS REQUESTS FOR SIGNAL UNDER CONTRACTOR MAINTENANCE

The Contractor shall mark any existing or newly installed underground conduits with paint & flags, within 24 hours of the direction of the Engineer.

STANDARD DRAWING:

Refer to the following supplemental specifications:
800 Dated: 1/15/2021

DESIGN SPECIFICATIONS:

This structure conforms to the 8th edition of the "LRFD Bridge Design Specifications" adopted by the American Association of State Highway and Transportation Officials, 2017 and ODOT Bridge Design Manual, 2020.

OPERATIONAL IMPORTANCE

A load modifier of 1.0 has been assumed for the design of this structure in accordance with the AASHTO LRFD bridge Design Specifications, article 1.3.5 and the ODOT Bridge Design Manual, 2020.

DESIGN LOADING

HL-93 truck with 60 psf future wearing surface
Headwalls: Earth pressure + live load surcharge
Wingwalls: Earth pressure + live load surcharge

DESIGN DATA

The following design data is assumed:

Internal angle of friction of backfill soil $\Phi_{bf} = 30^\circ$
Total unit weight of backfill soil = 120 pcf
Internal angle of friction (drained), foundation soil, $\Phi_f = 28^\circ$
Undrained shear strength (cohesive), foundation soil, $S_{ur} = 1500$ psf
Unit weight of concrete = 150 pcf
Slope of backfill = 2:1 where applicable
Height of live load surcharge = 2 ft. where applicable

Concrete class QC1 – Compressive strength 4000 psi (footing, wingwall, and foreslope wall)

Reinforcing steel – ASTM A615, 616, or A617 Grade 60 minimum yield strength 60,000 psi (all reinforcing shall be as reinforcing shall be epoxy coated)

Based on the assumed design data, the wingwalls achieve factored bearing resistances that are greater than their respective bearing pressures. If a backfill material with a higher internal angle of friction of lighter total unit weight is used; if a foundation soil with a higher drained internal angle of friction of a higher undrained shear strength is encountered; then the stability of the wingwalls is satisfactory.

PRECAST CONCRETE

At the option of the contractor, precast footings and wingwalls may be used provided they are sized to meet the soil parameters and meet or exceed the material strengths specified herein. The contractor shall submit designs and shop drawings to the County for approval.

FORESLOPE WALL ANCHOR DOWELS

Anchor per CMS 510 with nonshrink, nonmetallic grout conforming to CMS705.20 and to a depth specified on sheet 6 of 7. Payment for dowel holes, grout and installation shall be included with item 511.

As an alternative to resin bonding, threaded inserts of nonprotruding mechanical connectors cast into the culvert by the manufacturer may be used provided they can resist an ultimate pull-out strength of 12 kips and maintain a minimum cover of 3 inches at the bottom of the culvert slab. Mechanical connectors must provide an "L-shaped" bar inside the culvert with a minimum horizontal length of 12 inches. Payment for inserts or mechanical connectors shall be included with item 611.

POROUS BACKFILL WITH GEOTEXTILE FABRIC;

2'-0" thick shall be placed behind the wingwalls and shall extend to 12" below the embankment surface. Geotextile fabric shall be placed between the porous backfill and replaced excavation adjacent to the structure. It shall turn under the bottom of the porous backfill and return 6" above the top elevation of the weephole.

Weepholes shall be placed 6" to 12" above the normal water elevation or ground line and shall have a maximum spacing of 10'-0". A minimum of one weephole shall be provided per wingwall.

PREFORMED EXPANSION JOINT FILLER:

Preformed expansion joint filler (P.E.J.F.) conforming to CMS 705.03, 1 inch thick, shall be placed above the footing between the sides of the box culvert and the ends of the wingwalls. Payment for materials and installation shall be included with item 516 – 1" preformed expansion joint filler.

LOW STRENGTH MORTAR BACKFILL (TYPE 3), AS PER PLAN:

This work shall consist of the placement of a flowable material consisting of fly ash, with an expected 28 day unconfined compressive strength between 50 and 100 pounds per square inch (345–689kPa).

This item shall be placed at a slope of 1.5:1 starting from bottom of culvert to top of culvert. This item shall also be used for backfilling conduits or at other locations shown on the plans or as specified.

When pavement is to be placed on top of LSMBF, a minimum of 6" of compacted 304 aggregate shall be placed above LSMBF.

LOW STRENGTH MORTAR BACKFILL (TYPE 3), AS PER PLAN (CONTINUED):

Low strength mortar backfill is to be placed only from edge of pavement to edge of pavement. Place 2'-0" thick porous backfill with geotextile fabric behind wingwalls and remainder of culvert.

Include with item 613 – Low Strength Mortar Backfill (Type 3), As Per Plan for payment.

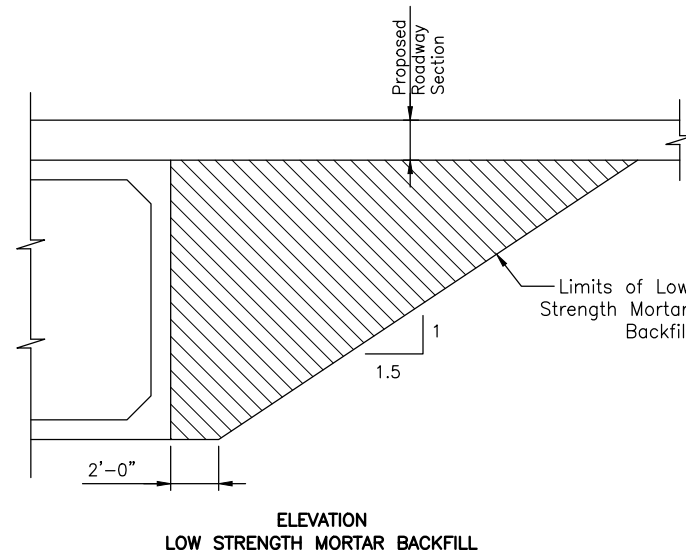
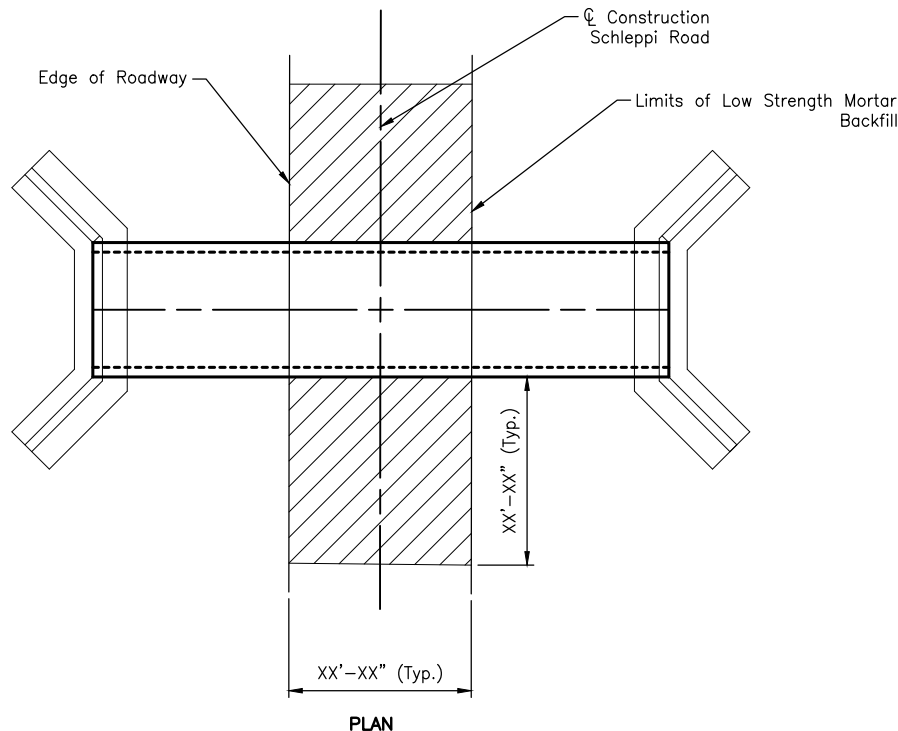

SEALING OF FORESLOPE WALL AND WINGWALLS:

All exposed foreslope wall and wingwall concrete shall be sealed with silane sealer. The limits shall be as shown in the diagrams below. Payment for the silane sealer shall be per item 512 – sealing of concrete surfaces.

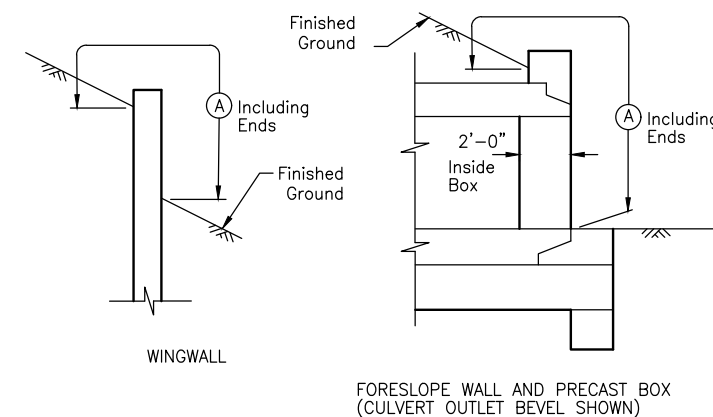

LIMITS OF ITEM 512—SEALING CONCRETE SURFACES

(A) – Seal entire concrete surface area

WATERPROOFING

Type 2 Waterproofing, per CMS 512.09 and 711.25, shall extend vertically down the entire sides of the precast culvert sections for all portions of the culvert which shall be in contact with the backfill. Payment for the membrane waterproofing shall be at the contract price bid per square yard for Item 512 – Type 2 Waterproofing.

Type 3 Waterproofing, per CMS 512.09 and 711.25 shall be applied to the entire top surface of the precast culvert sections and shall extend one foot vertically down the sides for all portions of the culvert which shall be in contact with the backfill. Payment for the membrane waterproofing shall be at the contract price bid per square yard for Item 512 – Type 3 Waterproofing.

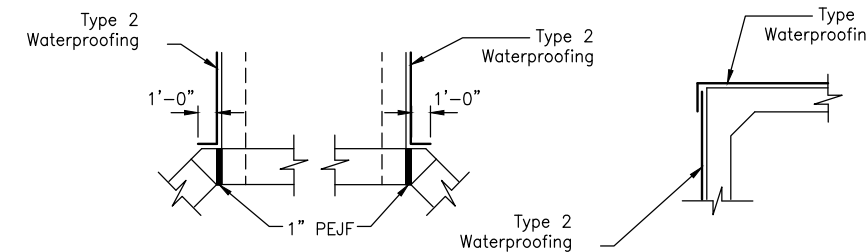

ITEM SPECIAL – CONDUIT, TYPE A, PRECAST REINFORCED CONCRETE ARCH INCLUDING HEADWALLS AND WINGWALLS, INSTALL ONLY, AS PER PLAN (0'-0" SPAN x 0'-0" RISE)

The contractor shall be responsible for the installation of the precast concrete system. The precast concrete system shall include XX'-XX" of precast reinforced concrete arch sections, wingwalls and headwalls. The bid price shall include all labor, equipment and any other item needed to properly install the precast concrete system as detailed in the plans. Precast footings are not allowed.

The precast concrete system will be available after award of the roadway project. The fabricator is to provide all components of the precast concrete system, including all hardware, mechanical components, bituminous joint sealer, and delivery to the project site. The contractor shall notify the fabricator at least 14 calendar days prior to the delivery date. The contractor shall be responsible for labor, equipment, and attachments to lift the sections off of the delivery trucks and subsequent installation. The contractor shall plan unloading and installation operations around existing overhead utility facilities.

Payment: The work for all the above shall be paid for at the contract lump sum unit bid price for item special – conduit, type a, precast reinforced concrete arch including headwalls and wingwalls, install only, as per plan (0'-0" span x 0'-0" rise). Price and payment shall be full compensation for all the labor, equipment, materials and incidentals necessary to complete this work in conformance with these requirements with pertinent provisions of item 603 and to the satisfaction of the Engineer.

DRAWING: P:\Plan_Review\FCEO_Standards\Design_Standards\General_Notes.dwg
January 24, 2025, 11:58am

DRAWN BY: JPM
CHECKED: KEA
DATE: 01/01/2025
BRIDGE / CULVERT NOTES
FRANKLIN COUNTY ENGINEER
18
20

FORMLINERS

Plasticized polyvinyl chloride formliners shall be used in forms for the vertical faces as shown on the plans. If the structure height is less than 4'-0" tall, use 4" border in lieu of 8".

Plasticized polyvinyl chloride formliners shall be as manufactured by the following companies or an approved equal formliner:

Greenstreak Architectural Formliner
Style no. 330 (Ashlar Stone)
Greenstreak, Inc.
3400 Tree Court Industrial Boulevard
St. Louis, MO 63122
(800)325-9504www.greenstreak.com

Thermoformed Formliner
P/c 230429 (Old Ashlar Stone)
Dayton Superior Corporation
7777 Washington Village Drive, Suite 130
Dayton, OH 45459
(888)977-9600www.daytonsuperior.com

Fitzgerald Vacuum-Formed Formliner
No. 16986 (Georgetown Ashlar)
Fitzgerald Formliners
1500 East Chestnut Avenue
Santa Ana, CA 92701
(800)547-7760www.formliners.com

Concrete for decorative facade form liner shall contain no. 8 coarse aggregate meeting ODOT-CMS section 703.02. The concrete shall be superplasticized. The slump for the concrete shall be 7 inches plus or minus 1 inch. The entrained air content shall be 6 percent plus or minus 2 percent.

Include with item 611 - conduit, type a, precast reinforced concrete box section, 12.00' span x 6.00' (rise), including wingwalls and footings, install only, as per plan.

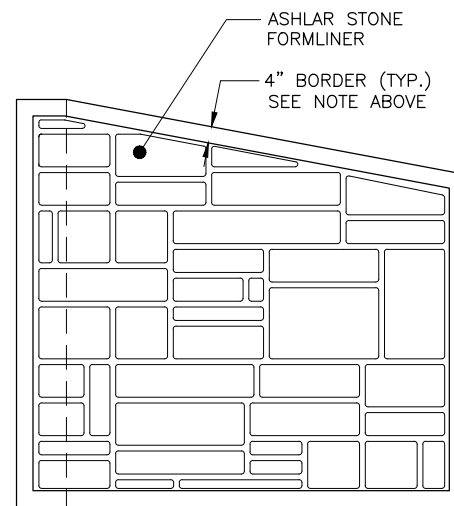

FORMLINER DETAIL
(DEVELOPED VIEW)

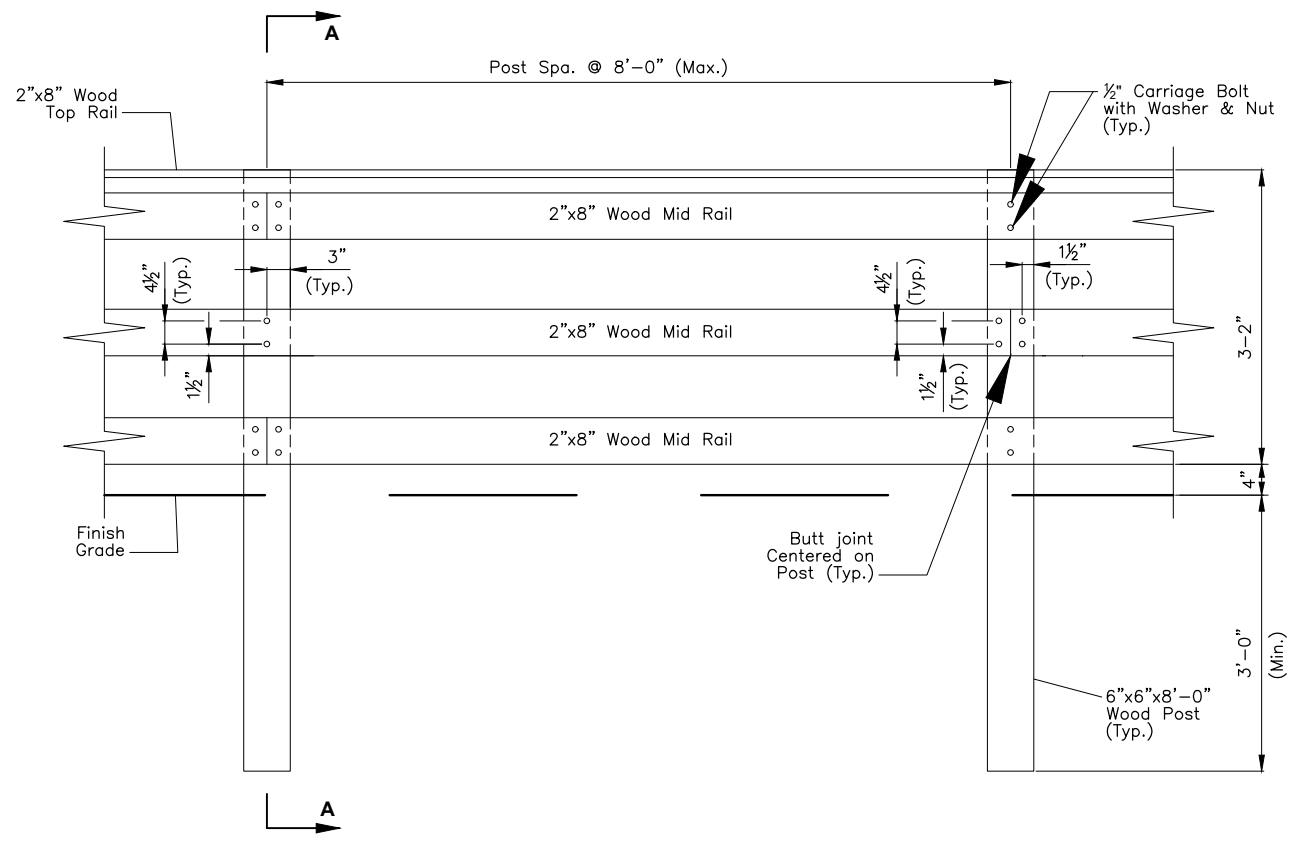

WOOD RAILING

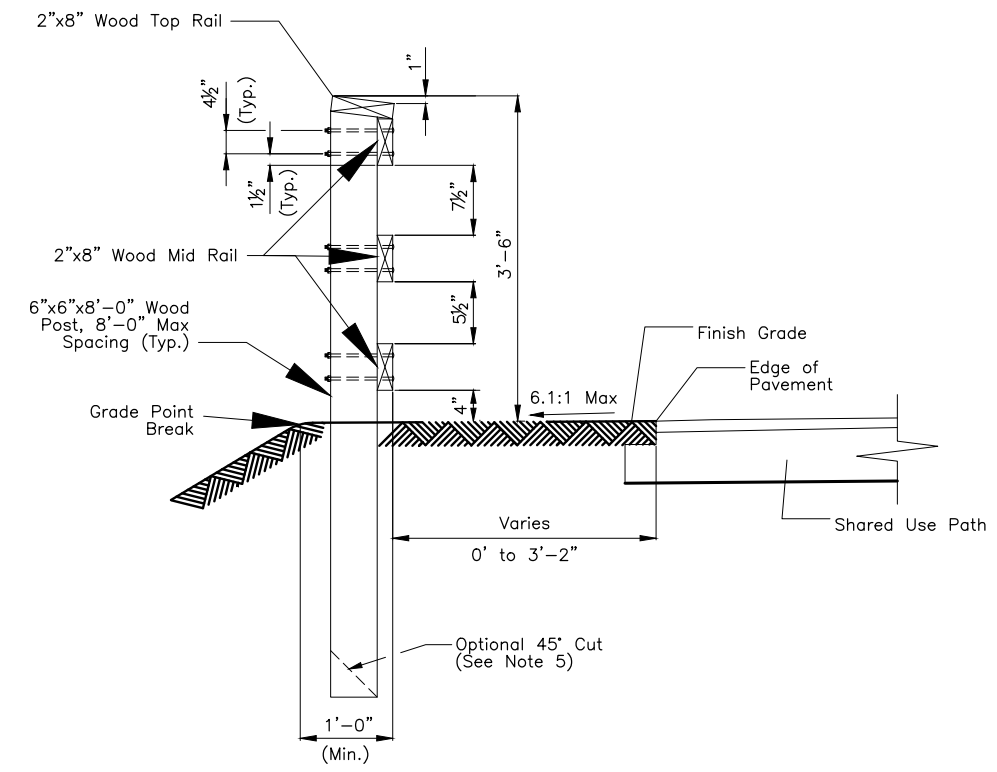

SECTION A-A

NOTES:

1. CCA TREAT ALL WOOD MEMBERS AS SPECIFIED IN CMS 712.06.
2. GALVANIZE ALL BOLTS, WASHERS, AND NUTS AS SPECIFIED IN CMS 711.02 AND 711.10. COUNTERBORE FACE OF RAILS TO PROVIDE FLUSH BOLT HEADS.
3. PROVIDE A WOOD RAILING THAT IS SMOOTH AND SPLINTER FREE.
4. WHERE LESS THAN 1'-0" OF GRADED SHOULDER WIDTH (10:1 OR FLATTER) EXTENDS BEYOND THE EDGE OF THE FACE RAIL, USE LONGER POSTS SO THAT A MINIMUM 5'-0" EMBEDMENT DEPTH IS PROVIDED.
5. THE BOTTOM END OF THE 6"x6" POSTS MAY BE CUT TO A 45 DEG. POINT.
6. STAGGER BUTT ENDS OF THE TOP RAIL AND THE LOWER FACE RAIL (ON ALTERNATE POSTS). CENTER ALL BUTT END JOINTS ON THE POSTS.
7. INCLUDE THE COST OF FURNISHING AND PLACING ALL POSTS, RAILS, AND HARDWARE IN THE UNIT PRICE BID FOR ITEM 607 -FENCE, MISC.: WOOD FENCE.
8. POST LOCATION STATION AND OFFSETS ARE AT THE CENTER OF THE RESPECTIVE POST.
9. ENDS SHALL BE OFFSET. DETAILS TO BE SPECIFIED IN PLANS.

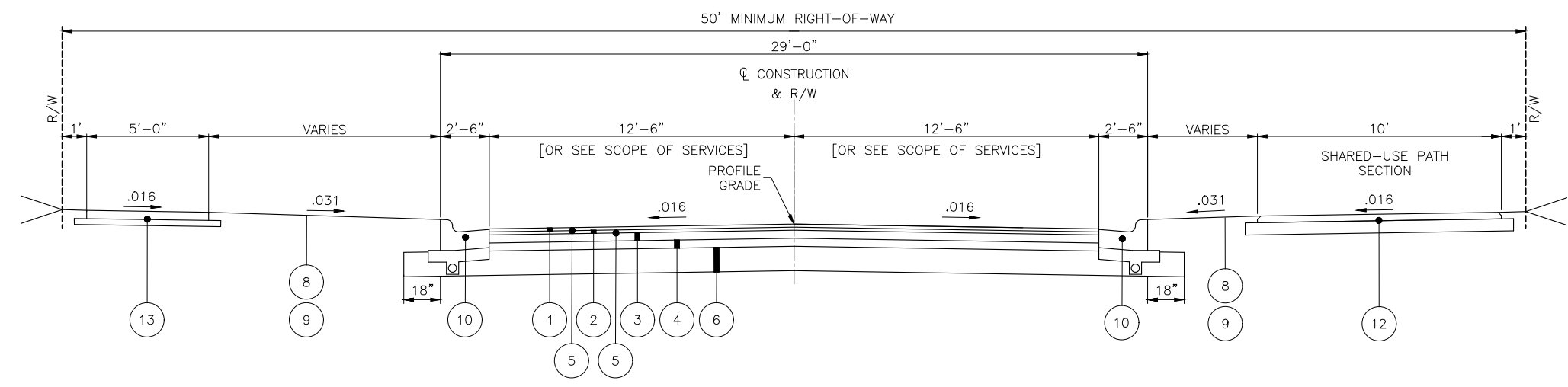

NORMAL FULL DEPTH SECTION
ROAD NAME
LIMITING STATIONS
 FROM STA. 00+0000 TO STA. 00+00.00 = 00.00 LIN FT.

NOTE:
 IF FCEO APPROVES 18" CURB IN PLACE
 OF CURB AND GUTTER, THE PAVEMENT
 WIDTH SHALL BE 28' F/F.

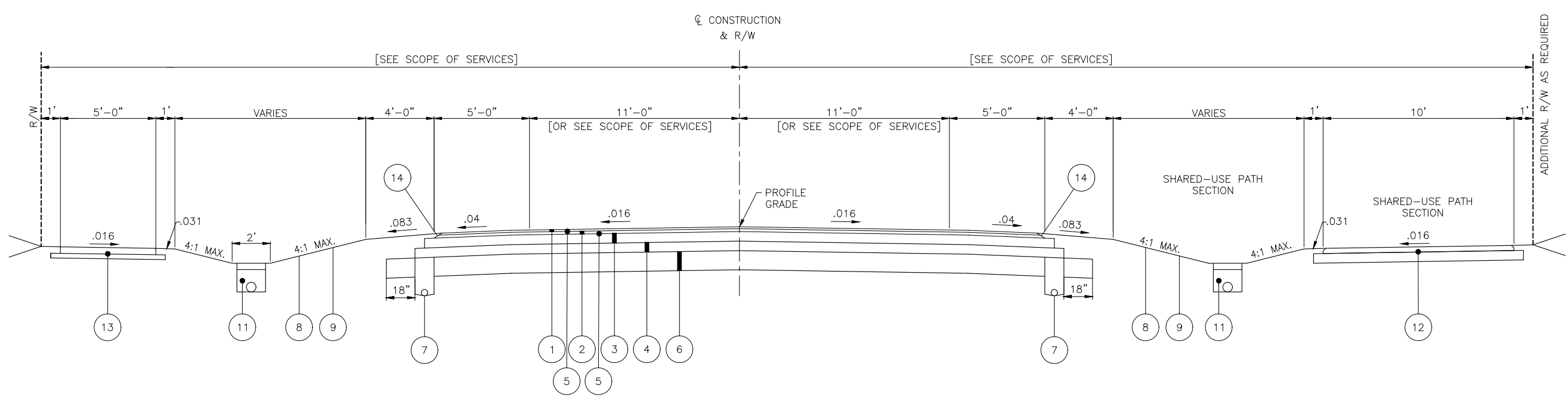

NORMAL FULL DEPTH SECTION
ROAD NAME
LIMITING STATIONS
 FROM STA. 00+0000 TO STA. 00+00.00 = 00.00 LIN FT.

- 1 ITEM 441 1-1/2" ASPHALT CONCRETE, SURFACE COURSE, TYPE 1, (448), PG64-22
- 2 ITEM 441 1-3/4" ASPHALT CONCRETE, INTERMEDIATE COURSE, TYPE 2, (448), PG64-22
- 3 ITEM 301 6" ASPHALT CONCRETE BASE, PG64-22 (2 LIFTS)
- 4 ITEM 304 6" AGGREGATE BASE
- 5 ITEM 407 NON-TRACKING TACK COAT (0.08 GAL/SQ YD)
- 6 ITEM 204 CEMENT STABILIZED SUBGRADE, 12" DEEP
- 7 ITEM 605 4" PIPE UNDERDRAIN - SEE FCEO STANDARD DRAWING RD-06

- 8 ITEM 653 TOPSOIL FURNISHED AND PLACED
- 9 ITEM 659 SEEDING AND MULCHING
- 10 ITEM 609 COMBINATION CURB AND GUTTER
- 11 ITEM 605 6" UNCLASSIFIED PIPE UNDERDRAIN - SEE FCEO STANDARD DRAWING RD-06
- 12 ITEM 608 SHARED-USE PATH - SEE FCEO STANDARD DRAWING RD-09
- 13 ITEM 608 CONCRETE SIDEWALK - SEE FCEO STANDARD DRAWING RD-09
- 14 SPECIAL PAVEMENT SAFETY EDGE - SEE FCEO STANDARD DRAWING RD-06

NOTE:
 SEE SCOPE OF SERVICES FOR SHARED-USE PATH
 AND SIDEWALK LOCATIONS

DRAWING: P:\Proj_Review\FCEO_Standards\Design_Standards\Standard_Drawings.dwg
 January 24, 2025, 11:11pm

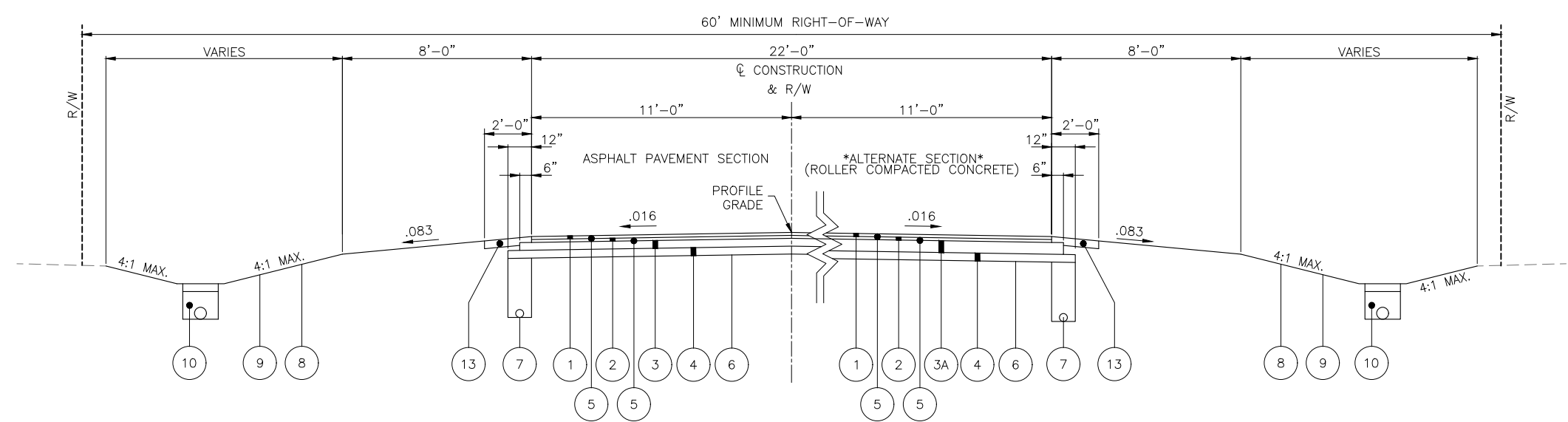

TYPICAL SECTION
 22' PAVEMENT SECTION
 LOCAL STREET
 OPEN DITCH

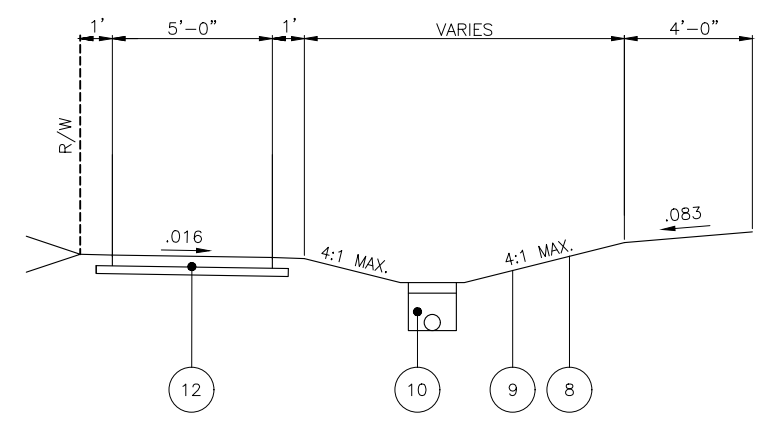

CONCRETE SIDEWALK
 SECTION

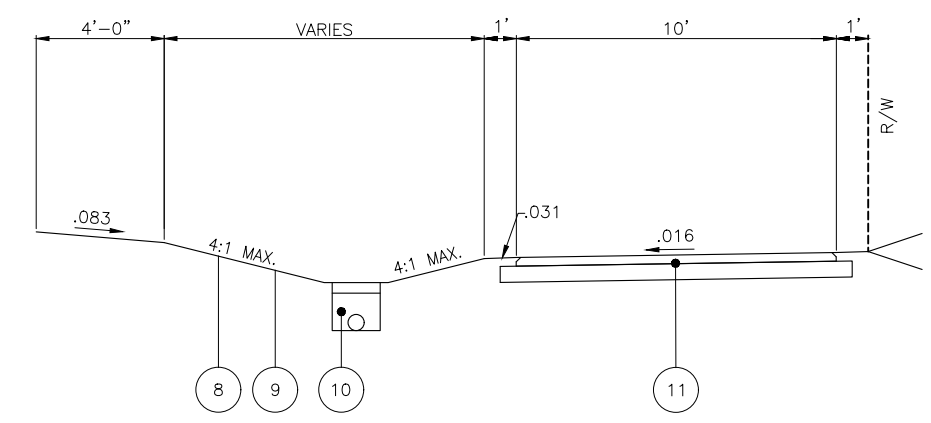

SHARED-USE PATH
 SECTION

- | | |
|---|--|
| ① ITEM 441 1-1/2" ASPHALT CONCRETE, SURFACE COURSE, TYPE 1, (448), PG64-22 | ⑦ ITEM 605 4" PIPE UNDERDRAIN - SEE FCEO STANDARD DRAWING RD-06 |
| ② ITEM 441 1-1/2" ASPHALT CONCRETE, INTERMEDIATE COURSE, TYPE 2, (448), PG64-22 | ⑧ ITEM 653 TOPSOIL FURNISHED AND PLACED |
| ③ ITEM 301 4" ASPHALT CONCRETE BASE, PG64-22 | ⑨ ITEM 659 SEEDING AND MULCHING |
| ③A CMSC SS-1523 6" ROLLER COMPACTED CONCRETE BASE | ⑩ ITEM 605 6" UNCLASSIFIED PIPE UNDERDRAIN - SEE FCEO STANDARD DRAWING RD-06 |
| ④ ITEM 304 4" AGGREGATE BASE | ⑪ ITEM 608 SHARED-USE PATH - SEE FCEO STANDARD DRAWING RD-09 |
| ⑤ ITEM 407 NON-TRACKING TACK COAT (0.08 GAL/SQ YD) | ⑫ ITEM 608 CONCRETE SIDEWALK - SEE FCEO STANDARD DRAWING RD-09 |
| ⑥ ITEM 204 SUBGRADE COMPACTION | ⑬ ITEM 411 STABILIZED CRUSHED AGGREGATE (T=4") |

DRAWING: P:\Proj_Review\FCEO_Standards\Design_Standards\Standard Drawings.dwg
 January 24, 2025, 11:13pm

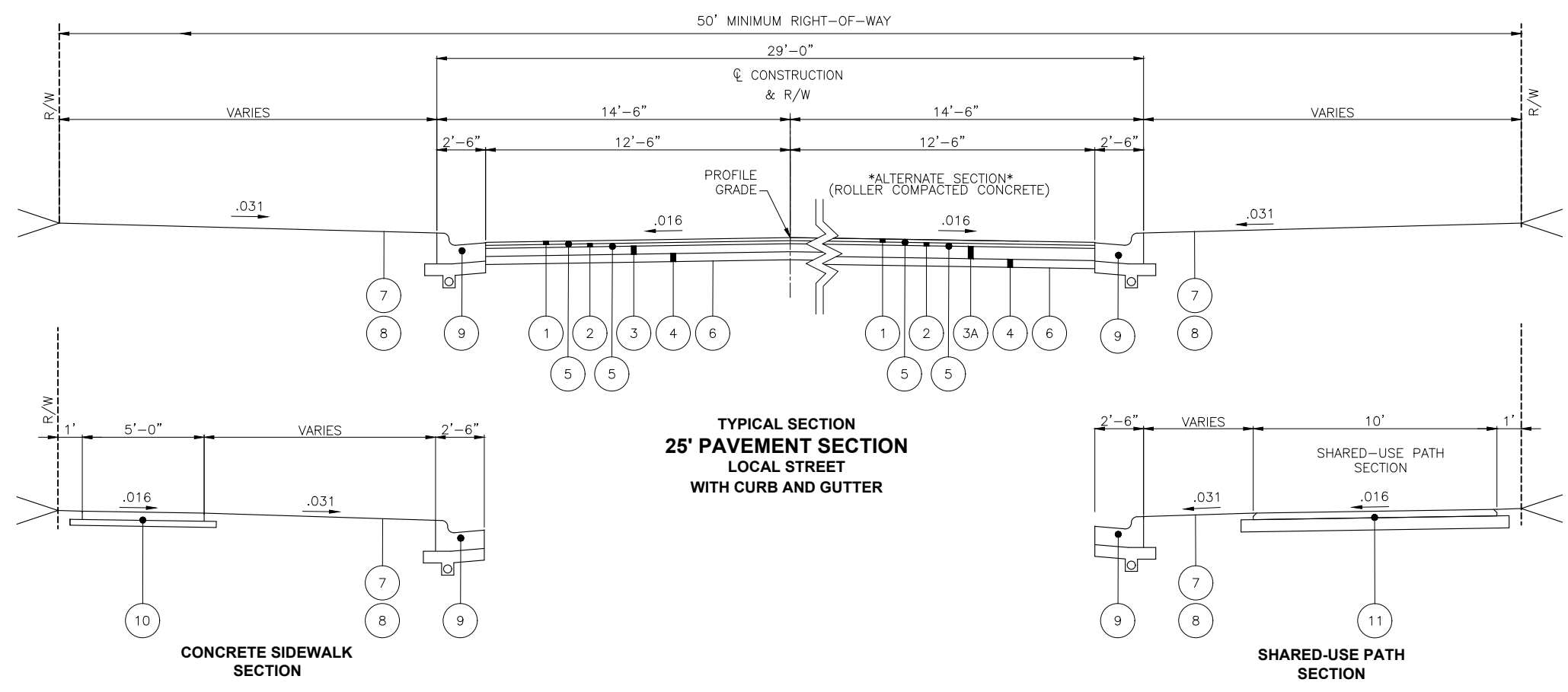

①	ITEM 441	1-1/2" ASPHALT CONCRETE, SURFACE COURSE, TYPE 1, (448), PG64-22	⑦	ITEM 653	TOPSOIL FURNISHED AND PLACED
②	ITEM 441	1-1/2" ASPHALT CONCRETE, INTERMEDIATE COURSE, TYPE 2, (448), PG64-22	⑧	ITEM 659	SEEDING AND MULCHING
③	ITEM 301	4" ASPHALT CONCRETE BASE, PG64-22	⑨	ITEM 609	COMBINATION CURB AND GUTTER
③A	CMSC SS-1523	6" ROLLER COMPACTED CONCRETE BASE	⑩	ITEM 608	CONCRETE SIDEWALK - SEE FCEO STANDARD DRAWING RD-09
④	ITEM 304	4" AGGREGATE BASE	⑪	ITEM 608	SHARED-USE PATH - SEE FCEO STANDARD DRAWING RD-09
⑤	ITEM 407	NON-TRACKING TACK COAT (0.08 GAL/SQ YD)			
⑥	ITEM 204	SUBGRADE COMPACTION			

DRAWING: P:\Proj_Review\FCEO_Standards\Design_Standards\Standard Drawings.dwg
 January 24, 2025, 11:13pm

TYPICAL PAVEMENT SECTION & SCHEMATIC PLAN FOR A ROUNDABOUT

FRANKLIN COUNTY ENGINEER
 STANDARD DRAWING

STD. DWG. NUMBER:
 RD - 04

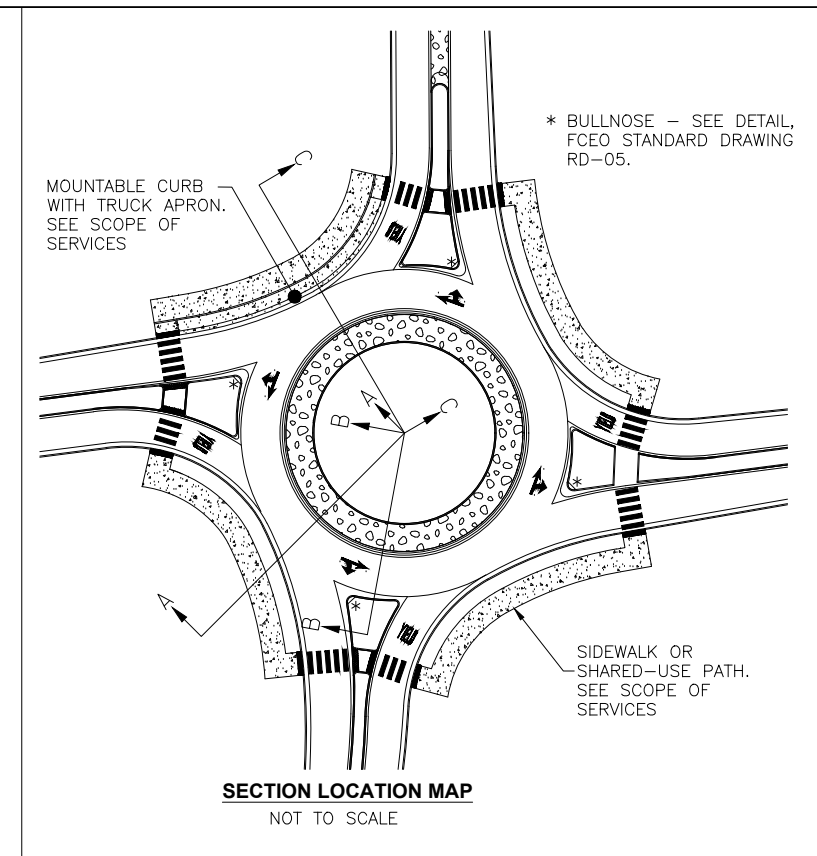
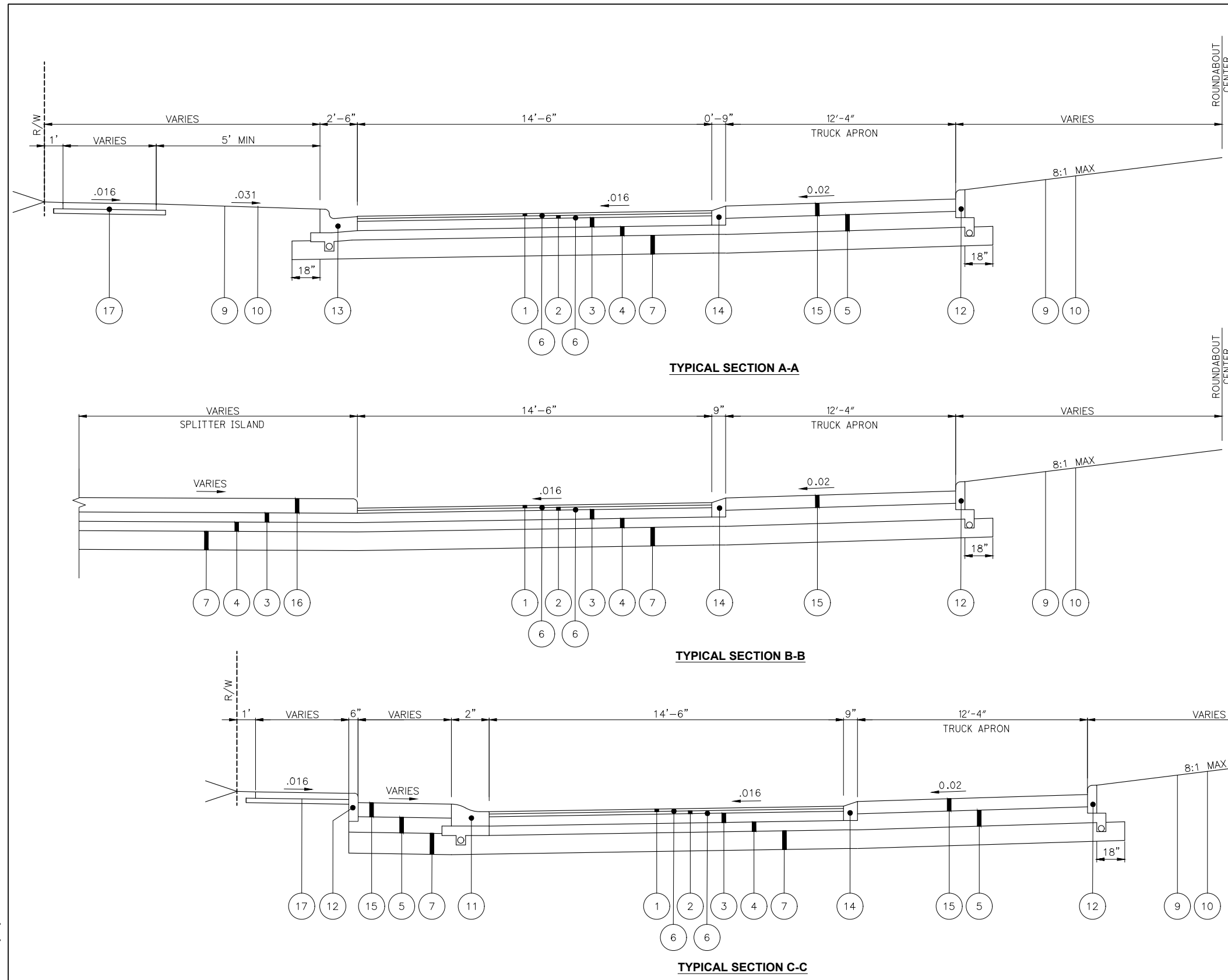

SECTION LOCATION MAP
 NOT TO SCALE

NOTES:
 SEE SCOPE OF SERVICES FOR SHARED-USE PATH AND SIDEWALK LOCATIONS

<p>① ITEM 441 1-1/2" ASPHALT CONCRETE, SURFACE COURSE, TYPE 1, (448), PG64-22</p> <p>② ITEM 441 1-3/4" ASPHALT CONCRETE, INTERMEDIATE COURSE, TYPE 2, (448), PG64-22</p> <p>③ ITEM 301 6" ASPHALT CONCRETE BASE, PG64-22 (2 LIFTS)</p> <p>④ ITEM 304 6" AGGREGATE BASE</p> <p>⑤ ITEM 304 10-1/4" AGGREGATE BASE</p> <p>⑥ ITEM 407 NON-TRACKING TACK COAT (0.08 GAL/SQ YD)</p> <p>⑦ ITEM 204 CEMENT STABILIZED SUBGRADE, 12" DEEP</p>	<p>⑧ ITEM 204 SUBGRADE COMPACTION</p> <p>⑨ ITEM 653 TOPSOIL FURNISHED AND PLACED</p> <p>⑩ ITEM 659 SEEDING AND MULCHING</p> <p>⑪ ITEM 609 MOUNTABLE CURB - SEE FCEO STANDARD DRAWING RD-07</p> <p>⑫ ITEM 609 STRAIGHT 18" CURB - SEE FCEO STANDARD DRAWING RD-07</p> <p>⑬ ITEM 609 COMBINATION CURB AND GUTTER</p> <p>⑭ ITEM 609 TRUCK APRON MOUNTABLE CURB - SEE FCEO STANDARD DRAWING RD-07</p>	<p>⑮ ITEM 452 8" STAMPED NON-REINFORCED CONCRETE PAVEMENT, ANDERSON CONCRETE COLOR C3150, BARK (OR APPROVED EQUAL.)</p> <p>⑯ ITEM 609 9.25" MONOLITHIC CONCRETE MEDIAN</p> <p>⑰ ITEM 608 SHARED-USE PATH OR SIDEWALK - SEE SCOPE OF SERVICES</p>
--	---	--

DRAWING: P:\Proj_Review\FCEO_Standards\Design_Standards\Standard Drawings.dwg
 January 24, 2025, 11:11pm

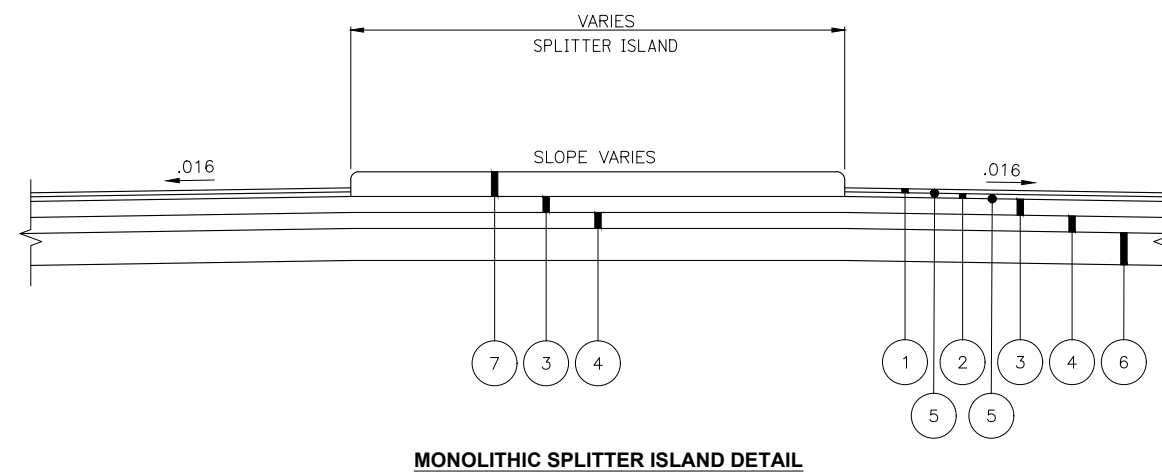
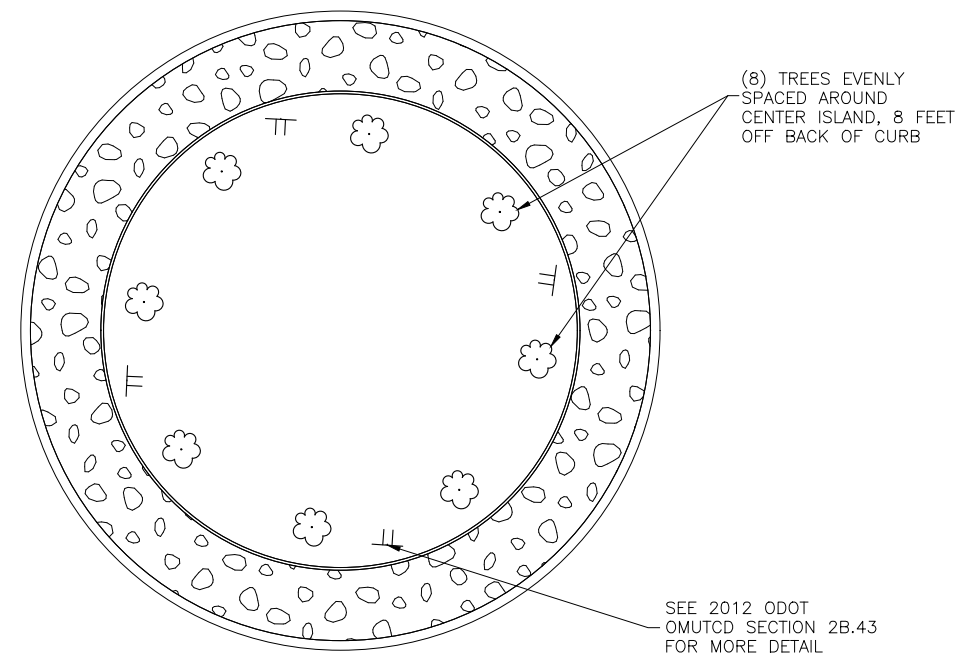
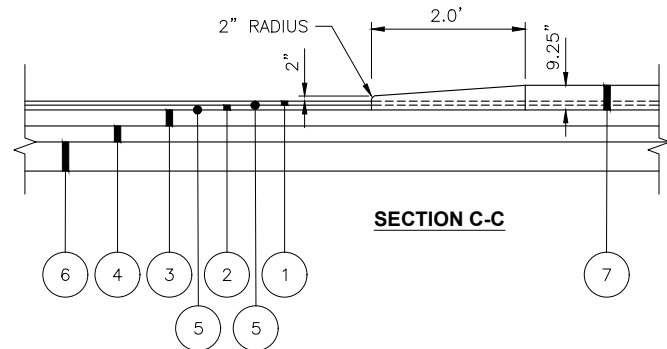
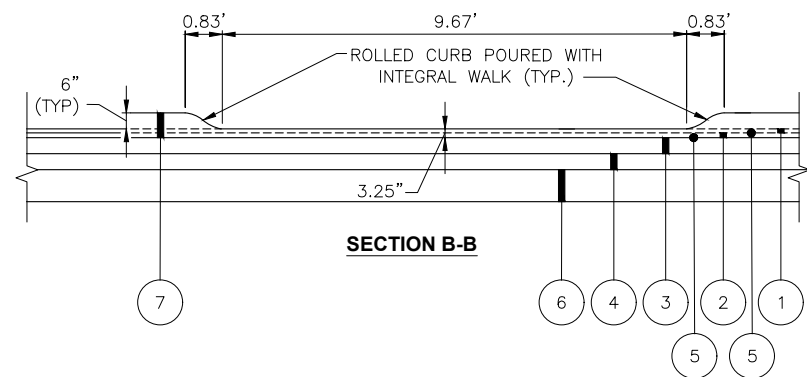
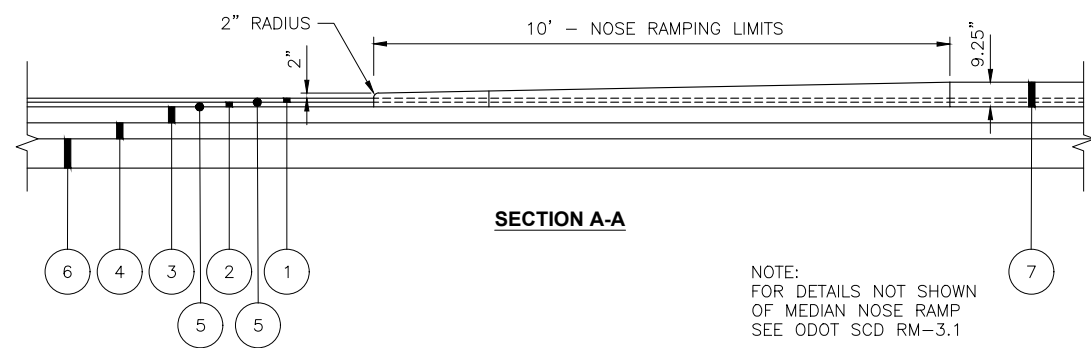
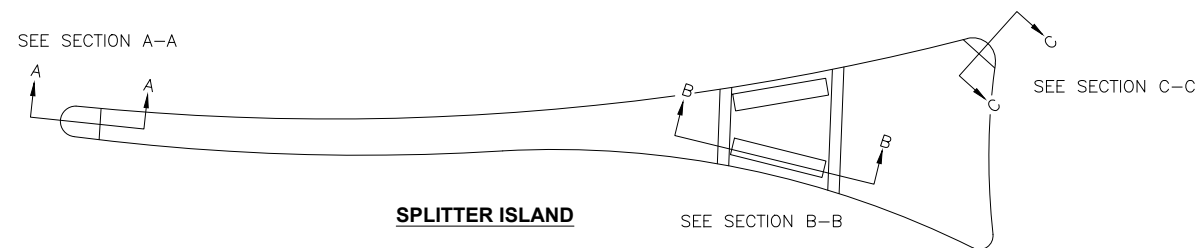

- ① ITEM 441 1-1/2" ASPHALT CONCRETE, SURFACE COURSE, TYPE 1, (448), PG64-22
- ② ITEM 441 1-3/4" ASPHALT CONCRETE, INTERMEDIATE COURSE, TYPE 2, (448), PG64-22
- ③ ITEM 301 6" ASPHALT CONCRETE BASE, PG64-22 (2 LIFTS)
- ④ ITEM 304 6" AGGREGATE BASE
- ⑤ ITEM 407 NON-TRACKING TACK COAT (0.08 GAL/SQ YD)
- ⑥ ITEM 204 CEMENT STABILIZED SUBGRADE, 12" DEEP
- ⑦ ITEM 609 9.25" MONOLITHIC CONCRETE MEDIAN

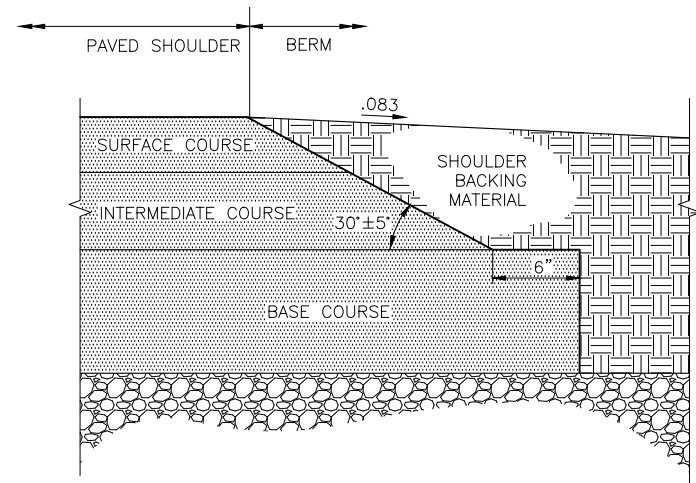

SAFETY EDGE PAVEMENT DETAIL
(INCLUDE WITH ASPHALT ITEMS FOR PAYMENT)

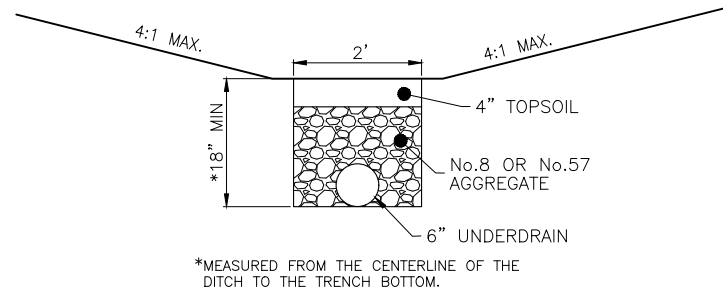

NOTE: PREFERRED LOCATION OF THE UNDERDRAIN IS OFFSET FROM THE CENTER OF THE DITCH IN THE BACKSLOPE (OR OPPOSITE THE SIDE OF THE SWALE THAT RECEIVES WATER) WITH 2' OF COVER OVER THE PIPE.

6" UNCLASSIFIED PIPE UNDERDRAIN DETAIL

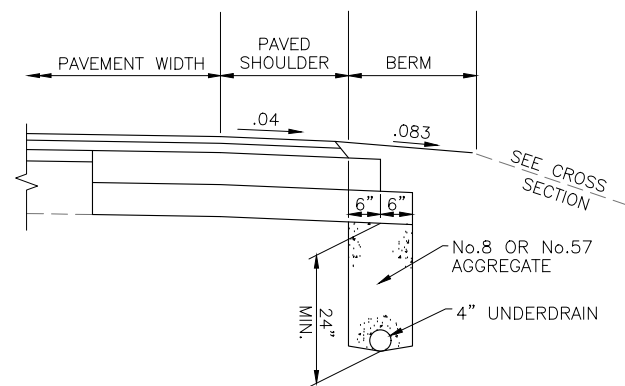

4" PIPE UNDERDRAIN DETAIL

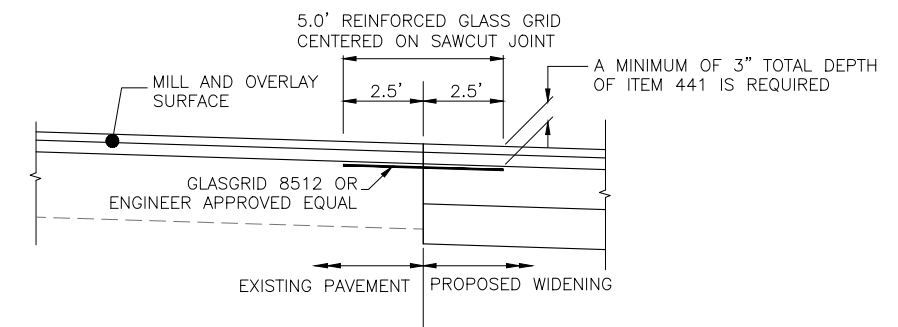

(a) FOR INTERMEDIATE COURSE & SURFACE COURSE ONLY
PAVEMENT REINFORCING GRID DETAIL

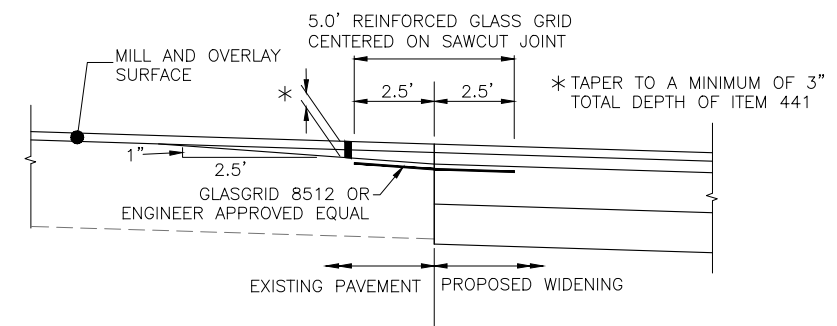

(b) FOR SURFACE COURSE OVERLAY ONLY
PAVEMENT REINFORCING GRID DETAIL

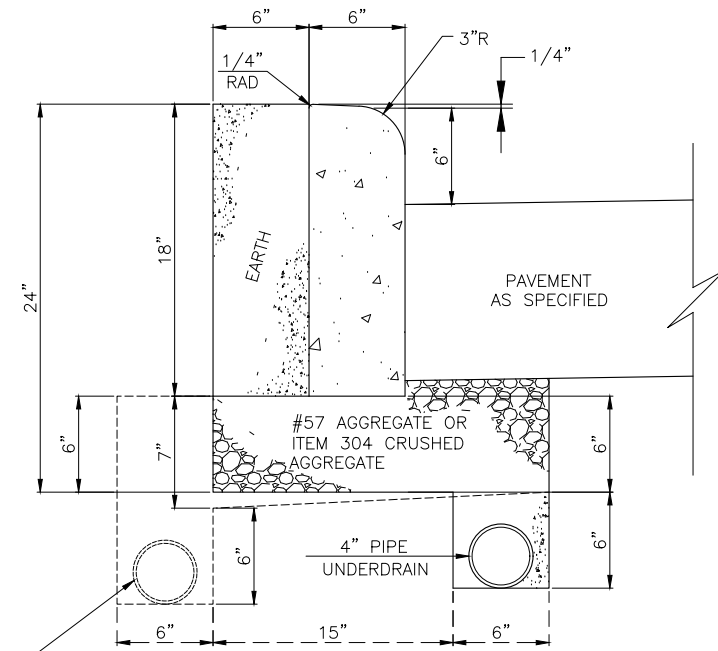

**STANDARD DETAIL
 STRAIGHT 18" CURB**

ALTERNATE 4" PIPE UNDERDRAIN LOCATION TO BE PLACED AS PER TYPICAL SECTION AND/OR AS DIRECTED BY THE ENGINEER.

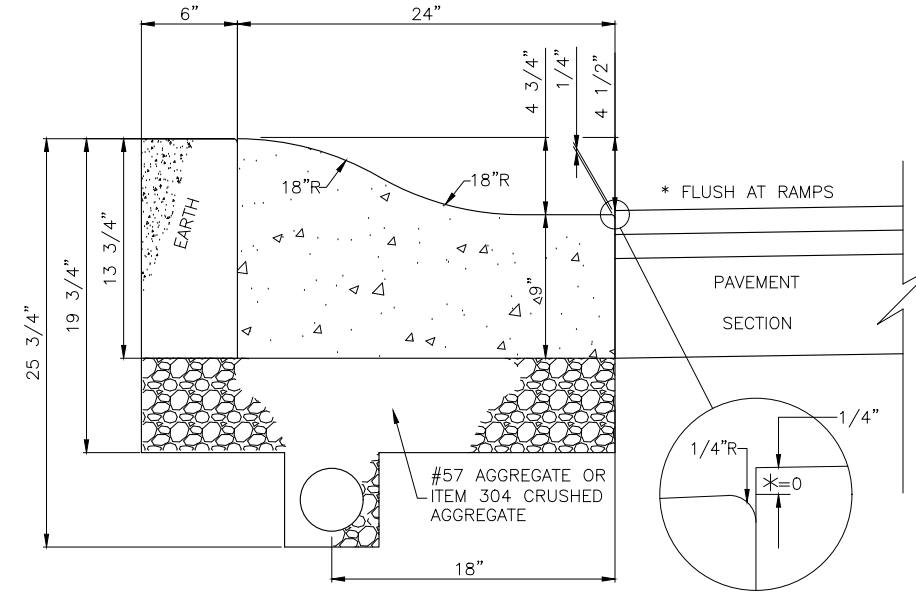

**STANDARD DETAIL
 MOUNTABLE CURB**

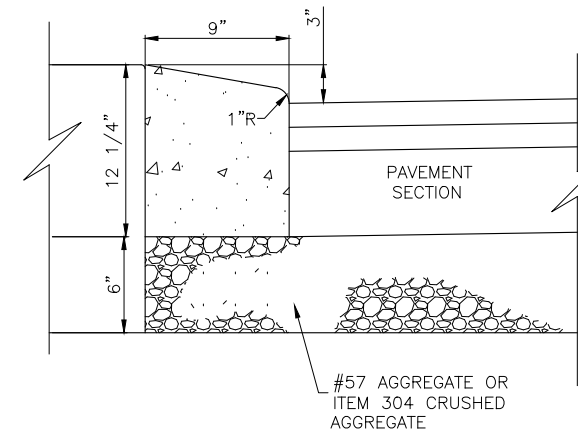

**STANDARD DETAIL
 TRUCK APRON MOUNTABLE CURB**

NOTES:

* THE PAVEMENT SHALL BE FLUSH AT THE GUTTER IN FRONT OF CURB RAMPS. CURB RAMPS SHALL BE BUILT AS PER CITY OF COLUMBUS STD. DWG. 2319.

ALL EXPOSED SURFACES OF CONCRETE CURB AND GUTTER SHALL HAVE A BRUSHED FINISH.

IF THE SUBGRADE IS MORE THAN 7" BELOW THE BOTTOM OF THE CURB, THE UNDERDRAIN SHALL BE ADJUSTED TO KEEP THE TOP OF THE UNDERDRAIN AT LEAST 2" BELOW THE SUBBASE.

SUBGRADE COMPACTION/CEMENT STABILIZATION SHALL BE COMPLETED BEFORE UNDERDRAIN INSTALLATION.

NOTE: WHEN A CURB AND GUTTER INLET IS INSTALLED, THE TOP OF THE BONNET SHALL BE THE SAME AS THE TOP OF CURB ELEVATION. THE EDGE OF PAVEMENT SHALL BE 3/8" HIGHER THAN THE GRATE WHEREVER THEY MEET/TOUCH.

FOR REPLACEMENT WORK, THE CURB SHALL BE REMOVED AT AN EXISTING JOINT OR NO CLOSER THAN 5 FEET FROM AN EXISTING JOINT.

1/2" EXPANSION MATERIAL WILL BE INSTALLED BEHIND THE CURB WHEN A CONCRETE WALK, DRIVE, OR OTHER ITEM IS ADJOINING IT.

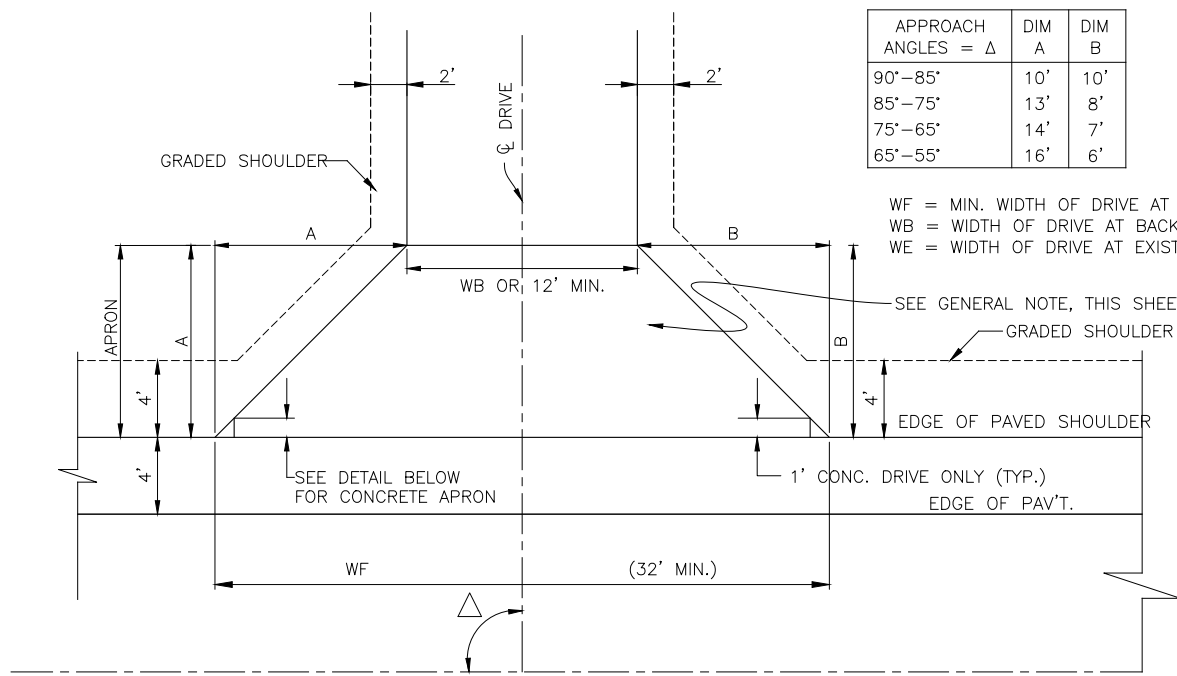

APPROACH ANGLES = Δ	DIM A	DIM B
90°-85°	10'	10'
85°-75°	13'	8'
75°-65°	14'	7'
65°-55°	16'	6'

WF = MIN. WIDTH OF DRIVE AT FRONT
 WB = WIDTH OF DRIVE AT BACK OF FLARE
 WE = WIDTH OF DRIVE AT EXISTING

DRIVEWAY DETAIL, TYPE 1

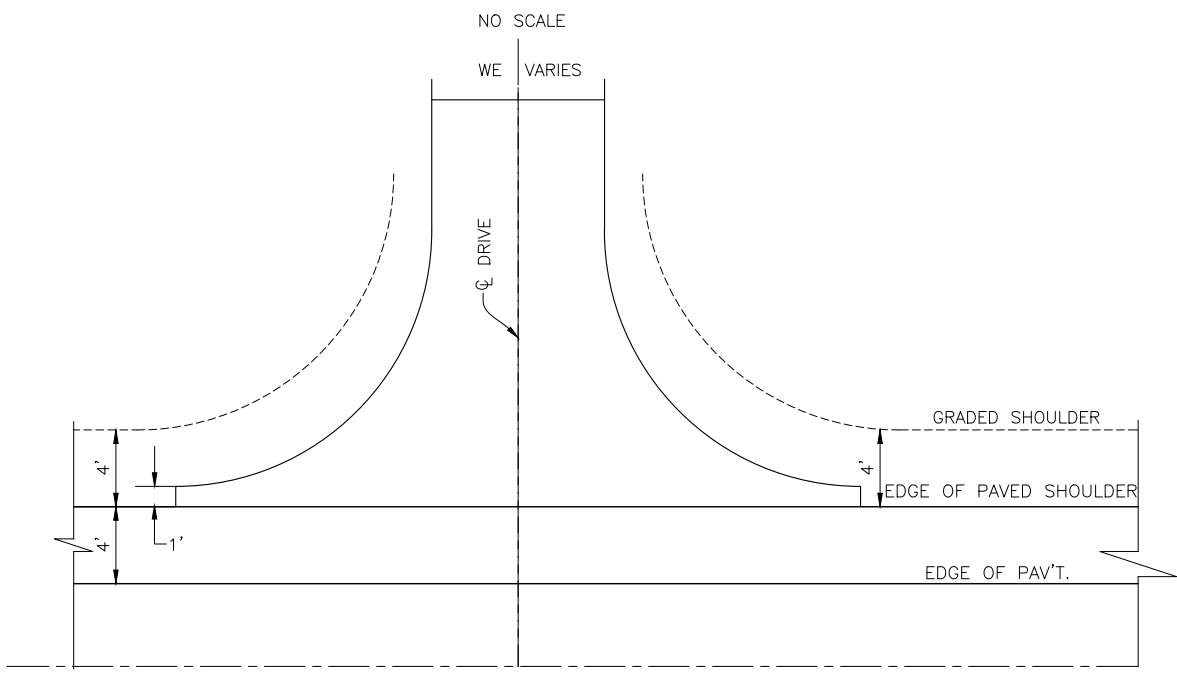

DRIVEWAY DETAIL, TYPE 2

DRIVEWAY TYPE	RESIDENTIAL		COMMERCIAL		INDUSTRIAL	
	DESIGN VEHICLE P		SU-30		WB-62/WB-67	
NOMINAL WIDTH ¹	MIN (FT)	MAX (FT)	MIN (FT)	MAX (FT)	MIN (FT)	MAX (FT)
ONE WAY DRIVE	12	14	14	20	14	26
TWO WAY DRIVE	12	24	26	32	26	38
CORRESPONDING RT RADIUS ²	25	15	35	20	75	50
TRAPEZOID	10'X10' FLARES		10'X10' FLARES		10'X10' FLARES	

¹DRIVEWAY THROAT WIDTH MEASURED PARALLEL TO HIGHWAY AND CLEAR OF THE TURN RADII
²RT RADIUS - RIGHT TURN RADIUS (NOTE: THE SMALLER THE DRIVE WIDTH, THE LARGER TURN RADIUS REQUIRED TO ACCOMMODATE THE PATH OF THE VEHICLE)
 P - PASSENGER CAR
 SU-30 - SINGLE UNIT TRUCK; 30 FEET IN LENGTH
 WB-62 - LARGE SEMI-TRAILER TRUCK; 68.2 FEET IN LENGTH
 WB-67 - INTERSTATE SEMI-TRAILER TRUCK; 74 FEET IN LENGTH

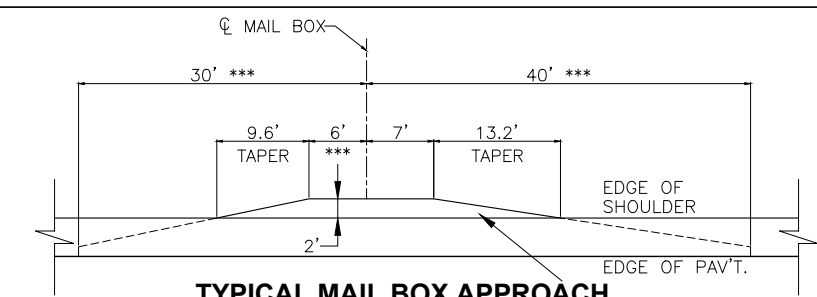

TYPICAL MAIL BOX APPROACH
(INDEPENDENT OF DRIVEWAY)

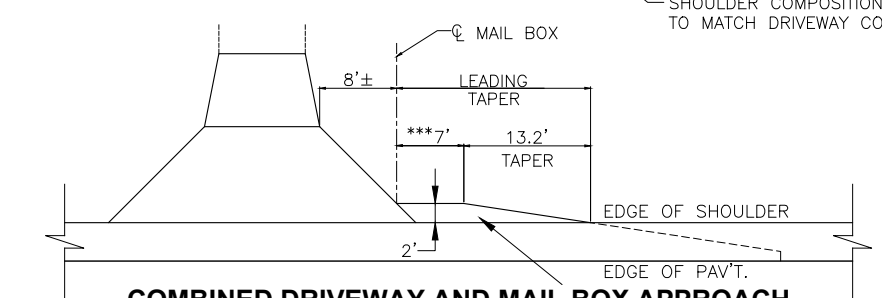

COMBINED DRIVEWAY AND MAIL BOX APPROACH
(LEADING APPROACH)

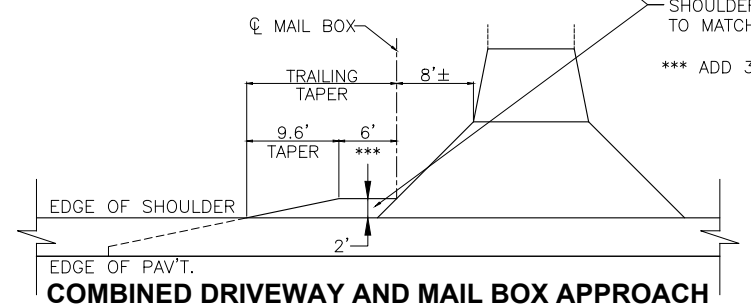

COMBINED DRIVEWAY AND MAIL BOX APPROACH
(TRAILING APPROACH)

GENERAL
CONCRETE APRON REQUIRED, REGARDLESS OF EXISTING OR PROPOSED DRIVEWAY COMPOSITION, IF WITHIN A CONCRETE CURBED SECTION OF ROADWAY.

ASPHALT APRON REQUIRED FOR DISTANCE OF 4' FROM THE EDGE OF THE ROADWAY'S ASPHALT PAVEMENT, REGARDLESS OF EXISTING (OR PROPOSED) DRIVEWAY COMPOSITION, IF WITHIN NON-CONCRETE CURBED SECTION OF ROADWAY. THE REMAINING 6' OF THE APRON SHALL BE ASPHALT IF THE EXISTING (OR PROPOSED) DRIVEWAY IS ASPHALT OR GRAVEL. THE REMAINING 6' OF THE APRON SHALL BE CONCRETE IF EXISTING (OR PROPOSED) DRIVEWAY IS CONCRETE.

ADA
REFER TO CURRENT CITY OF COLUMBUS STANDARD DRAWINGS 2319 DR. A OR LOCAL JURISDICTION STANDARDS. CONCRETE SIDEWALKS EXTENDING THROUGH DRIVEWAYS SHALL BE 8" THICK.

DRIVE CULVERTS
HEADWALLS/ENDWALLS ARE NOT REQUIRED BECAUSE THEY CREATE A HAZARD IN THE RIGHT-OF-WAY. FLARES MAY BE REQUIRED IF IT IS APPROPRIATE FOR THE LOCATION. REINFORCED CONCRETE PIPE (RCP) (706.02) WITH TYPE B INSTALLATION WILL BE REQUIRED WHEN THERE IS LESS THAN 1' OF COVER OVER THE TOP OF THE PIPE. GRAY HIGH-PERFORMANCE PLASTIC PIPE (HP) (POLYPROPYLENE CORRUGATED DOUBLE WALL PIPE 707.65), TYPE B OR RCP TYPE B MAY BE USED WHEN THE COVER OVER THE TOP OF THE PIPE EXCEEDS 1'. 12" MINIMUM PIPE DIAMETER PIPE IS REQUIRED.

RIGHT-IN, RIGHT-OUT ONLY DRIVEWAYS
ODOT ACCESS MANAGEMENT MANUAL - CURRENT EDITION.
CITY OF COLUMBUS - STD. DWG. 2330

MAIL BOX APPROACHES
FOR ADDITIONAL DETAILS ON MAIL BOX APPROACHES SEE ODOT STD DWG BP-4.1

RESIDENTIAL COMPOSITION
WIDTH-MINIMUM 12' (WB) AT BACK OF APRON AND 32' AT FRONT.
LENGTH-10' STARTING AT BACK OF CURB OR SHOULDER.
FLARES-SEE APPROACH ANGLE TABLE.

ASPHALT DRIVE
ITEM 441-3" ASPHALT CONCRETE SURFACE COURSE, TYPE I (448 DRIVEWAYS) PG64-22
ITEM 304-6" AGGREGATE BASE

CONCRETE DRIVE
ITEM 452-6" CLASS MS CONCRETE
ITEM 304-6" AGGREGATE BASE

GRAVEL AND FIELD DRIVES
APRON AREA
ITEM 441-3" ASPHALT CONCRETE SURFACE COURSE, TYPE I (448 DRIVEWAYS) PG64-22
ITEM 304-6" AGGREGATE BASE

BEHIND APRON
ITEM 304-9" AGGREGATE BASE

COMMERCIAL COMPOSITION
MATCH EXISTING SHAPE IF POSSIBLE

WIDTH-VARIES DEPENDING ON USE
LENGTH-VARIES DEPENDING ON USE
FLARES-VARIES DEPENDING ON USE

ASPHALT DRIVE
ITEM 441-3" ASPHALT CONCRETE SURFACE COURSE, TYPE I (448 DRIVEWAYS) PG64-22
ITEM 407-NON-TRACKING TACK COAT
ITEM 301-4" ASPHALT CONCRETE BASE
ITEM 304-4" AGGREGATE BASE

CONCRETE DRIVE
ITEM 452-8" CLASS MS CONCRETE
ITEM 304-6" AGGREGATE BASE

DRAWING: P:\Proj_Review\FCEO_Standards\Design_Standards\Standard_Drawings.dwg
January 24, 2025, 11:11pm

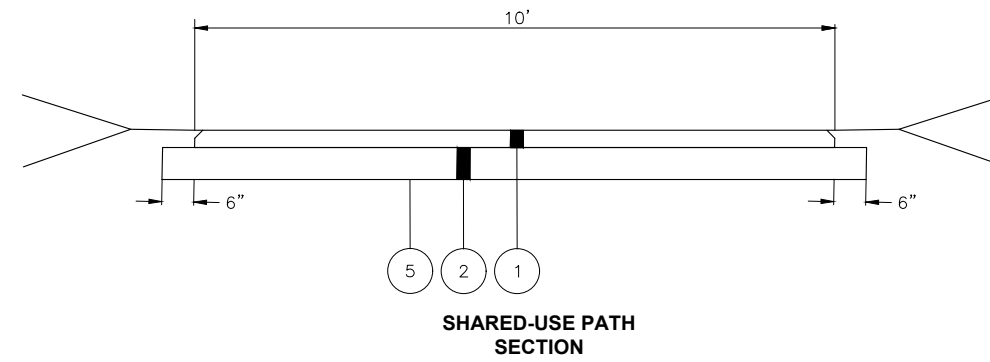
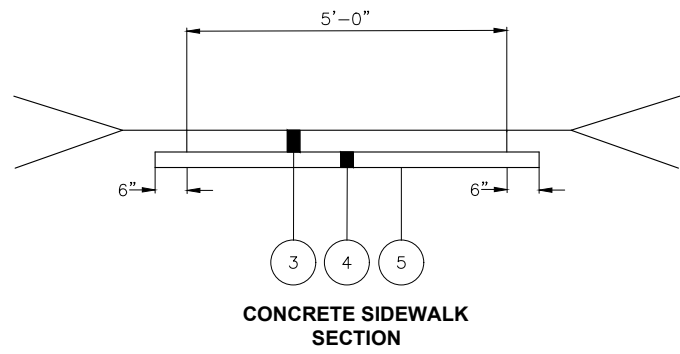

- ① ITEM 441 3" ASPHALT CONCRETE, SURFACE COURSE, TYPE 1, (448), PG64-22
- ② ITEM 304 6" AGGREGATE BASE
- ③ ITEM 608 CONCRETE WALK (T=4")
- ④ ITEM 203 EMBANKMENT USING NO. 57 STONE (4")
- ⑤ ITEM 204 SUBGRADE COMPACTION

NOTES:

ALL ADA SIDEWALK AND SHARED-USE PATH RAMPS SHALL MEET ODOT ADA REQUIREMENTS.

SEE ODOT STANDARD DRAWING BP-7.1_2023-01-20 FOR CURB RAMP DETAILS.

WATER AND UTILITY BOXES IN THE SIDEWALK OR SHARED-USE PATH AREA SHALL BE ADJUSTED FLUSH WITH THE FINAL SURFACE.

WHERE NEW WALK ABUTS ADJOINING WALK, SAWCUT EXISTING WALK TO THE NEAREST JOINT AND INSTALL EXPANSION JOINT PER ITEM 608.03

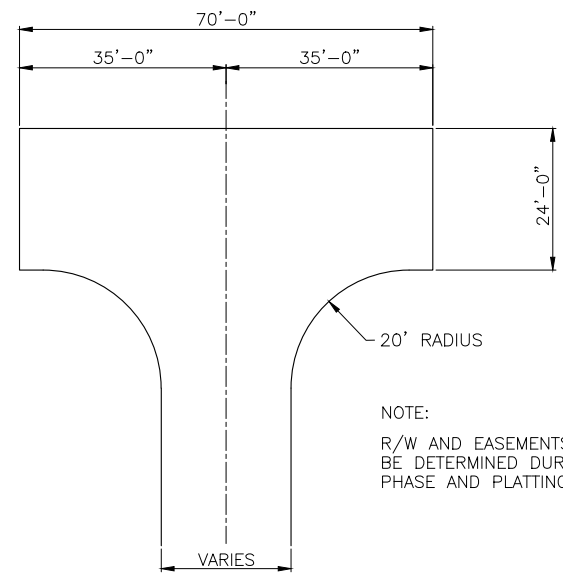

**STANDARD DETAIL
TEMPORARY "T"
TURN-A-ROUND**

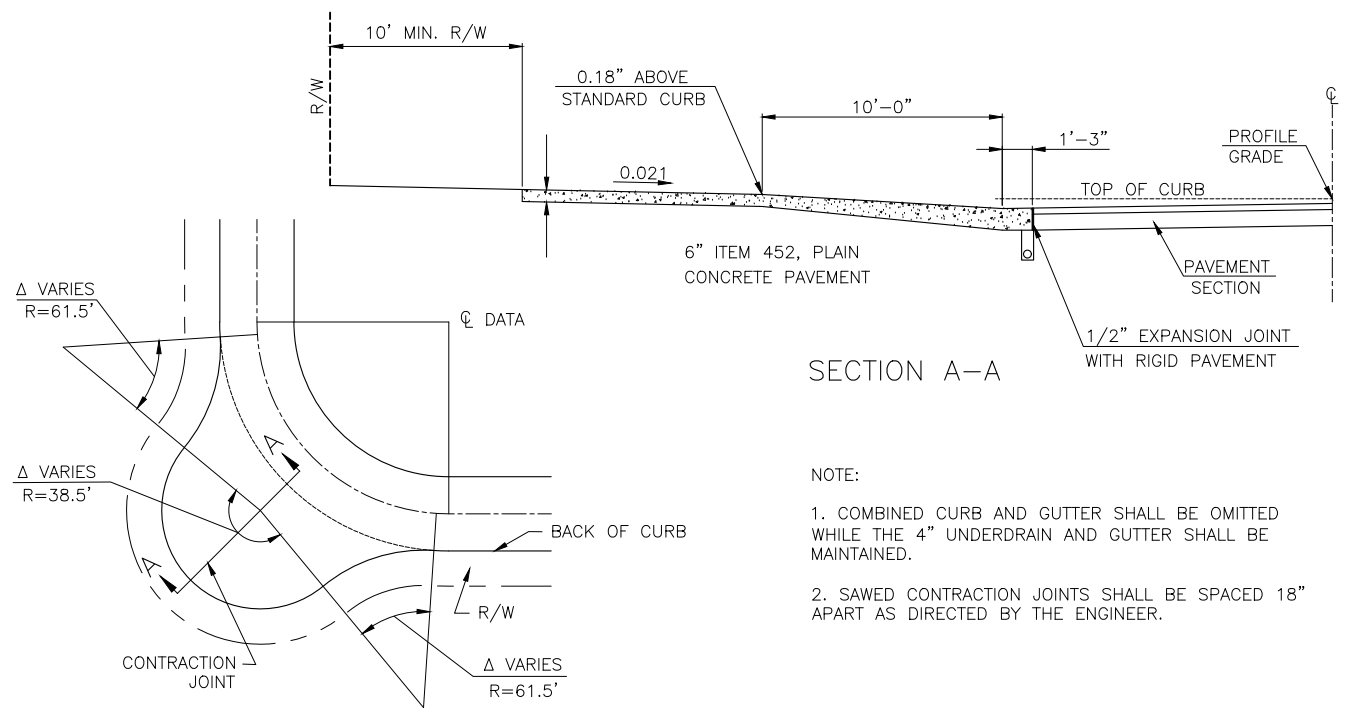

**STANDARD DETAIL
EYEBROW TYPICAL SECTION
INDUSTRIAL STREET
WITH OPEN DITCH**

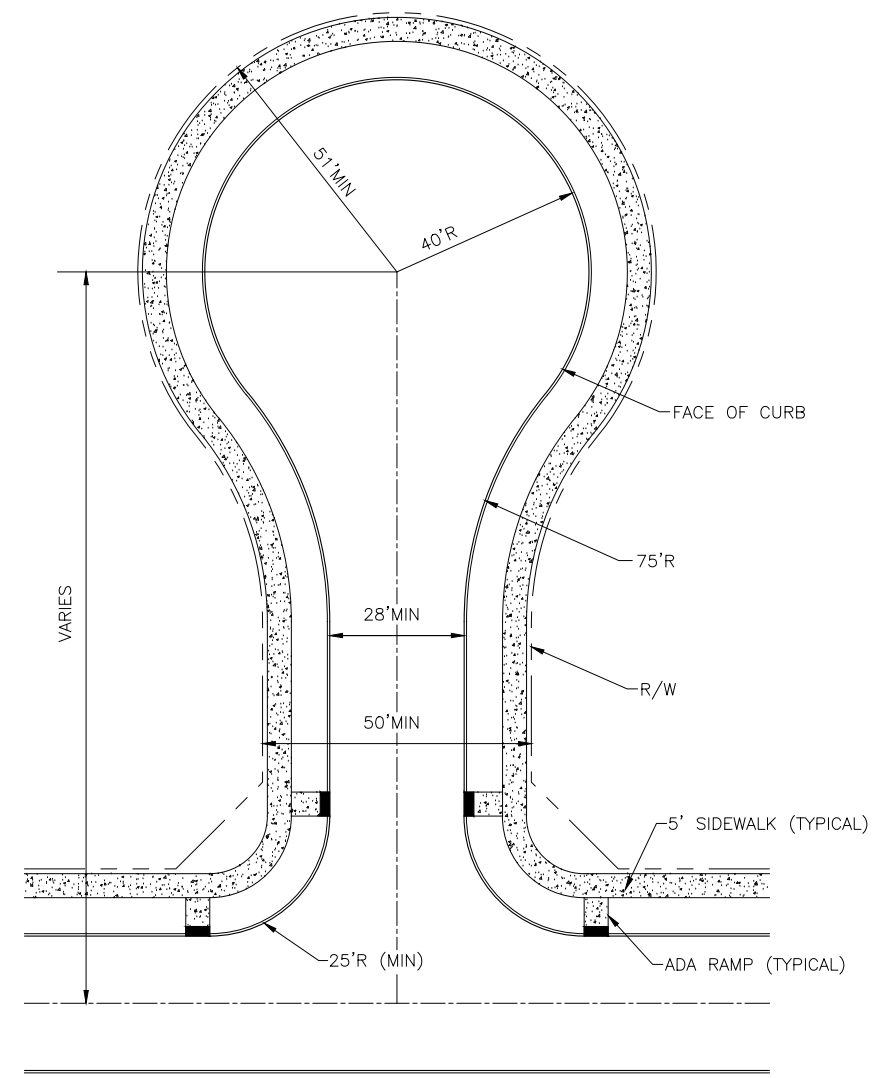

**STANDARD DETAIL
CURBED CUL-DE-SAC**

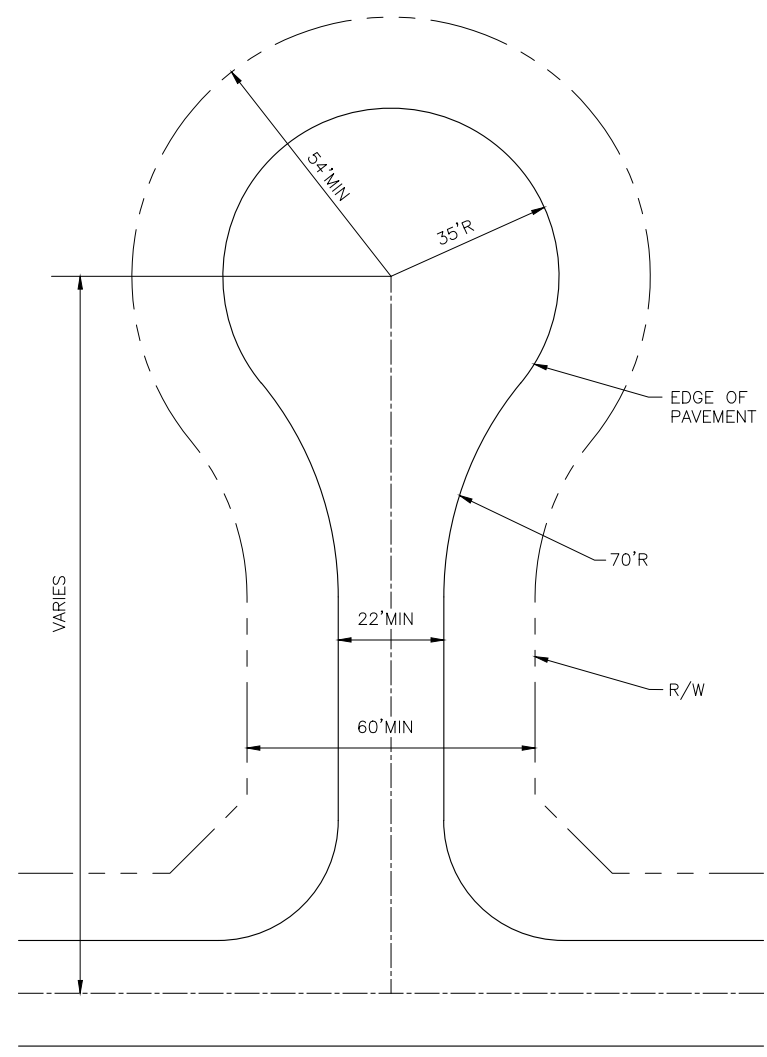

**STANDARD DETAIL
UNCURBED CUL-DE-SAC**

DRAWING: P:\Proj_Review\FCEO_Standards\Design_Standards\Standard_Drawings.dwg
January 24, 2025, 11:11pm

DRAWN BY: ACK
DATE: 01/01/2025
CHECKED: JDH

CUL-DE-SAC, EYEBROW & TURN-AROUND DETAILS

**FRANKLIN COUNTY ENGINEER
STANDARD DRAWING**

STD. DWG. NUMBER:
RD - 10